

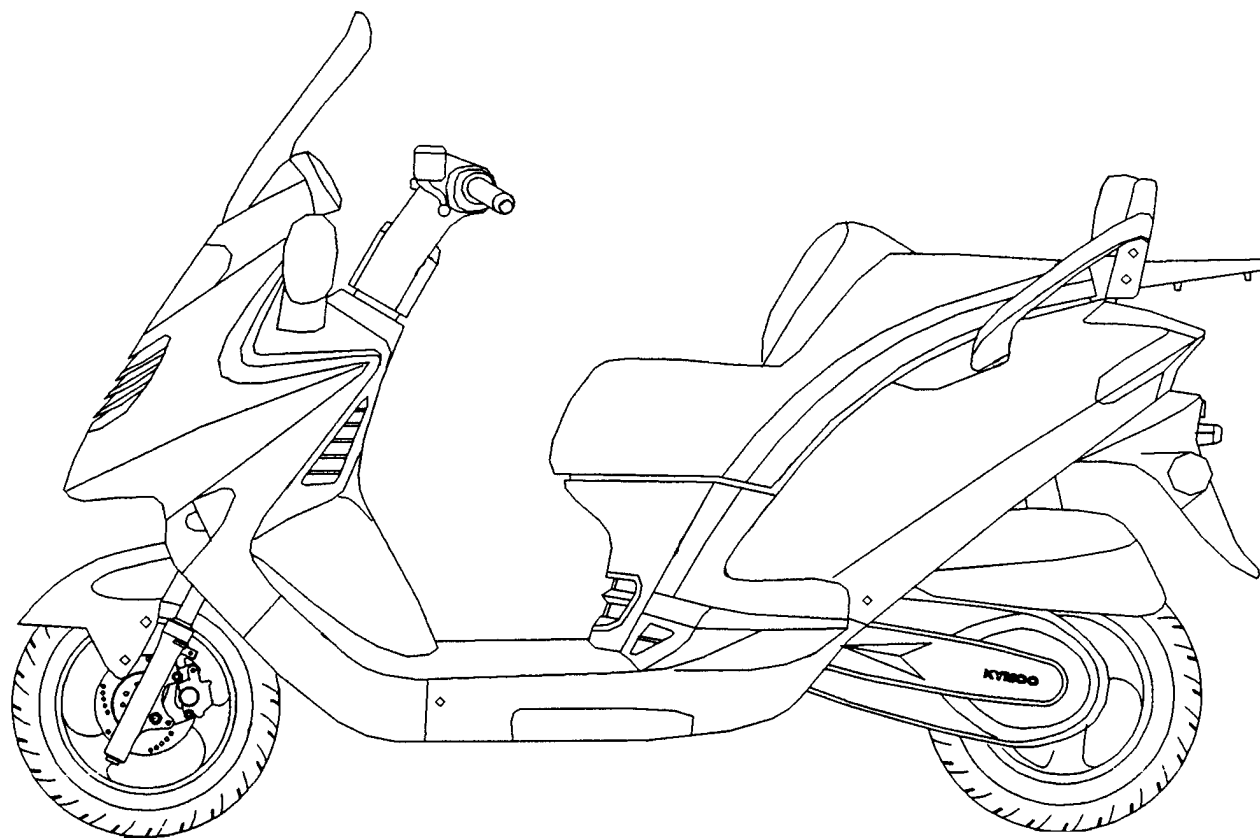

GRAND DINK

零件型錄
PARTS CATALOGUE

SH25DB(AT) JUN/ 20 /03' 制訂



光陽機車

KYMCO

光陽機車

KYMCO

光陽機車

KYMCO

前 言

- 本零件目錄適用於 SH25DB(AT) 機種，訂購零件時，請參照本冊。
- 本冊之配色表僅供參考，若與實車不符之處，以實車為準。
- 販賣記號(Sales mark)：
 - 1、註明 ★★ 記號，表示訂購該零件時，請參照機車相片及配色表，並請在基本零件號碼最後加上色碼。
 - 2、註明 ★ 記號，表示該零件為補修零件。
- 本冊付梓印刷倉促，倘有錯誤或遺漏之處，敬請不吝賜教指正。

ABOUT THIS PARTS LIST

- This parts list is compiled all service parts for model SH25DB(AT)。
- Any difference between color chart and motorcycle will be revised according to motorcycle。
- The sales mark：
 - 1、marking "★★" must add color code in the end before ordering parts。
 - 2、marking "★" is a saleable item。
- When modification or additions to this parts list are made a revised edition at an appropriate time。

目 次

●前 言	1
●SH25DB(AT)配色表	5
●引擎分組圖	7
●車架分組圖	9
●引擎零件號碼表	13
●車架零件號碼表	51
●零件號碼索引	133

CONTENTS

●ABOUT THIS PARTS LIST	1
●COLOR CHART OF SH25DB(AT).....	5
●CONTENTS-ENGINE GROUP	7
●CONTENTS-FRAME GROUP	9
●ENGINE PARTS LIST	13
●FRAME PARTS LIST	51
●PART NO. INDEX	133

		機種名稱 (MODEL)		SH25DB(AT) COLOR CHART					
項	相片號碼 (PHOTO NO)			NO.1	NO.2	NO.3	NO.4	NO.5	NO.6
次	主體色 (BASIC COLOR)			亮銀	深鐵灰	深藍	豔紅	黃綠	藍
NO	色碼 (CODE)			Bright Silver	Dark Gray Metallic	Deep Blue Metallic	Ruby Red	Yellow Green	Blue Metallic
	色別零件名稱(PARTS NAME)	基本零件號碼(PARTS NO)	版數(VERSION)	NH045MA	NH124MA	PB183MA	RR004CA	YG025MA	PB023MA
1	COVER SCREEN	64301-KKC4-900	0	N8P	NFP	BHP	R1P	W3P	B4P
2	COVER SET R SIDE	83500-KKC4-900	0						
3	COVER SET L SIDE	83600-KKC4-900	1						
4	MIRROR ASSY R BACK	88110-KKC3-900	4						
5	MIRROR ASSY L BACK	88120-KKC3-900	4						
6	SKIRT R SIDE	64305-KKC4-900	1						
7	SKIRT L SIDE	64306-KKC4-900	2						
8	MOLDING FR	64302-KKC4-900	0						
9	FENDER FRONT	61110-KHD8-900	2						
10	COWL UNDER	64400-KKC4-900	0						
11	COVER RR CENTER	83750-KKC4-900	1	N8P					
12	METER COVER FR	37203-KKC3-900	0						
13	METER COVER RR	37204-KKC3-900	0						
14	COVER R HANDLE LOW	53206-KKC4-900	0						
15	COVER L HANDLE LOW	53207-KKC4-900	0						
16	LEG SHIELD	81131-KKC4-900	0						
17	LID LEG SHIELD	81132-KEB7-900	0						
18	FLOOR PANEL	64310-KKC4-900	0						
19	COVER R PILLION STEP	64311-KKC4-900	3						
20	COVER L PILLION STEP	64321-KKC4-900	2						
21	MAT FLOOR	64320-KKC4-900	0	N1R					
22	LID RESERVE TANK	81136-KKC4-900	0						
23	GRID R LEG SHIELD	53214-KKC4-900	0						
24	GRID L LEG SHIELD	53224-KKC4-900	0						
25	GRIP R PILLION STEP	64312-KKC4-900	3						
26	GRIP L PILLION STEP	64322-KKC4-900	1						
27	COVER METER	53204-KKC4-900	2						
28	COVER CENTER	80151-KKC4-900	0						
29	GRID R LEG SHIELD	81137-KKC4-900	0						
30	GRID L LEG SHIELD	81147-KKC4-900	0						
31	LEVER R STRG HNDL	53175-KFA5-E10	0	M3A					
32	LEVER L STRG HNDL	53178-KFC8-E10	0						
33	COVER HANDLE UP	53205-KKC4-900	0	N8P					
34	GRILL HANDLE UP	53208-KKC4-900	0						
35	COVER L	11341-KKC3-900	0	N8A					
36	GRIP R HANDLE	53140-KKC3-900	0						
37	GRIP L HANDLE	53166-KGB5-900	0	N1R					
38	SIDE R GRIP	81400-KKC4-900	0						
39	SIDE L GRIP	81500-KKC4-900	0						
40	COVER BATTERY	50326-KKC4-900	0	NJA					
41	CALIPER ASSY RR	43100-KBE-910	0						
42	BODY CALIPER FR	45200-KKC2-E00	1						
43	WHEEL FR CAST	44650-KHD8-30A	1						
生產日期 (DATE OF STARTING-SALES)				2003.11.21			2003.11.21		2003.11.21

生產日期 (DATE OF STARTING-SALES)	2003.11.21			2003.11.21		2003.11.21
停產日期 (DATE OF ENDING-SALES)						

CONTENTS-ENGINE GROUP

E1 曲軸箱 -15-
Crank Case

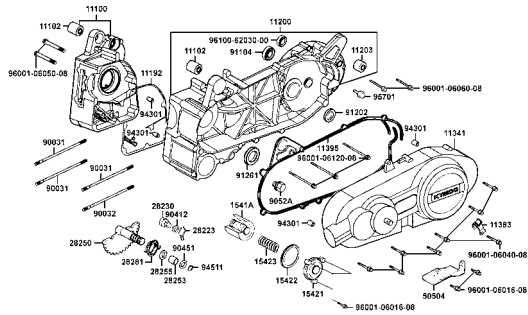

E2 汽缸頭蓋●汽缸頭 -19-
Cylinder Head Cover●Cylinder Head

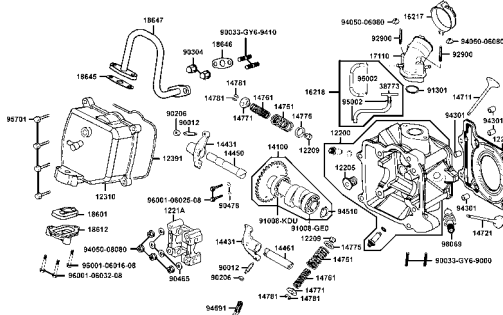

E3 汽缸●活塞●曲軸 -25-
Cylinder●Piston●Crankshaft

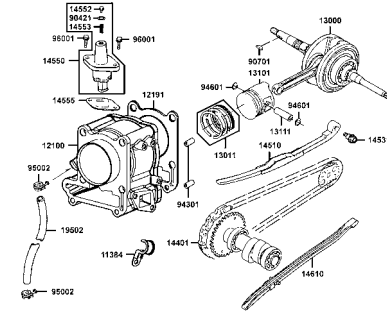

E4 右曲軸箱蓋●水泵 -29-
Right Crankcase Cover●Water Pump

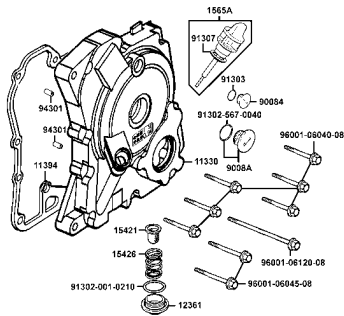

E5 傳動系 -31-
Transmission

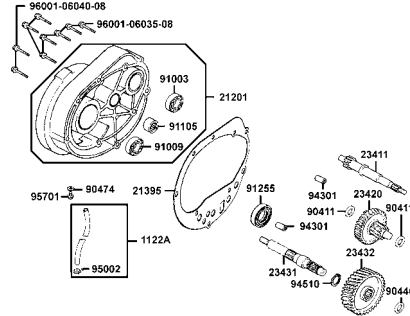

E6 傳動皮帶輪 -33-
Driven Pulley

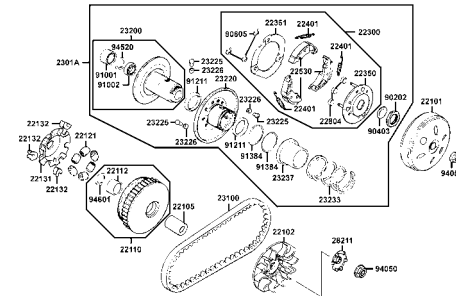

E7 起動馬達●機油泵 -37-
Starting Motor●Oil Pump

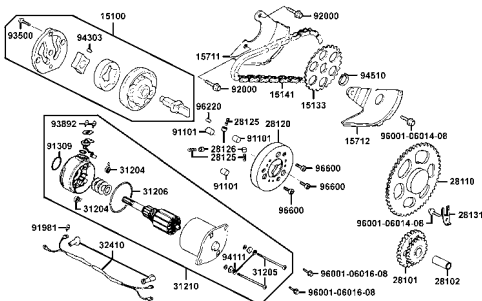

E8 發電機●水泵 -41-
Generator●Water Pump

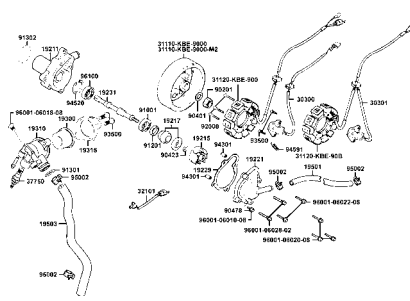

E9 化油器 -45-
Carburetor

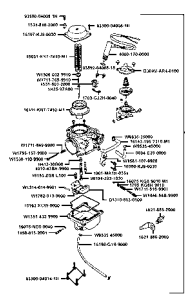

CONTENTS-FRAME GROUP

F1 前燈 -53-
Head Light

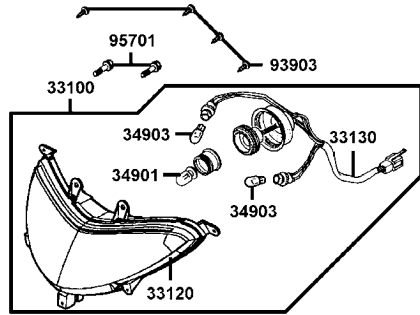

F2 儀錶 -55-
Speedometer

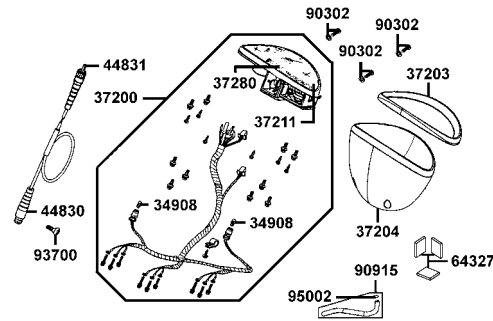

F3 轉向手柄●手柄蓋 -57-
Handle Steering●Handle Cover

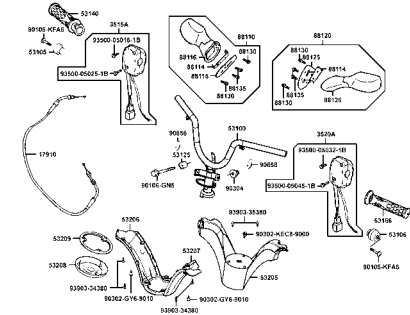

F4 煞車主油缸 -61-
Brake Master Cylinder

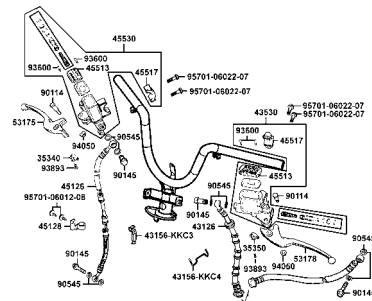

F5 前護蓋●腳踏板 -65-
Front Cover●Floor Panel

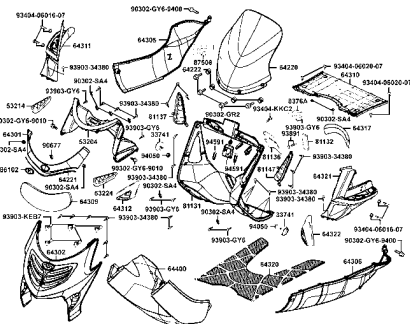

F6 前避震器 -71-
Front Cushion

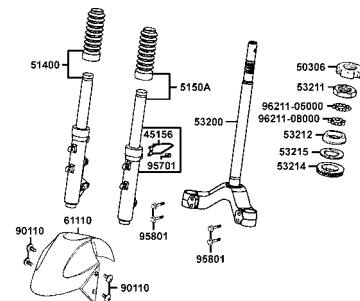

F7 前輪 -73-
Front Wheel

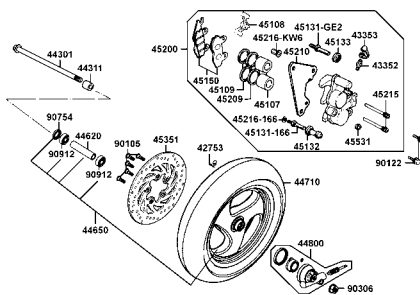

F8 後輪 -77-
Rear Wheel

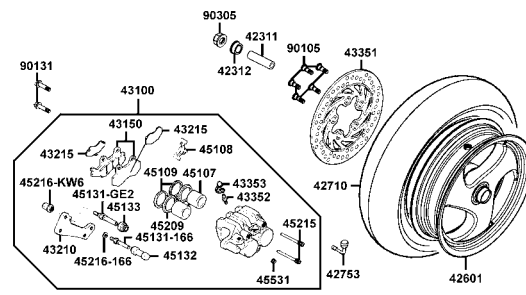

F9 座墊 -81-
Seat

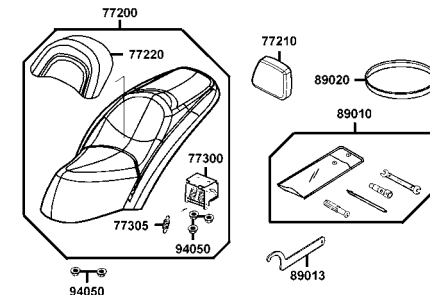

CONTENTS-FRAME GROUP

F10 油箱
Fuel Tank -83

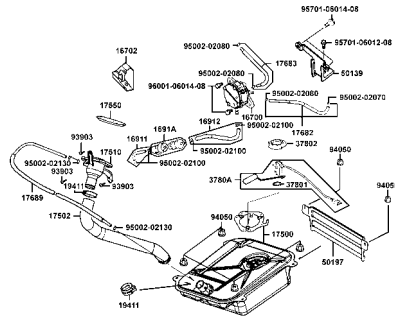

F11 電瓶
Battery -87-

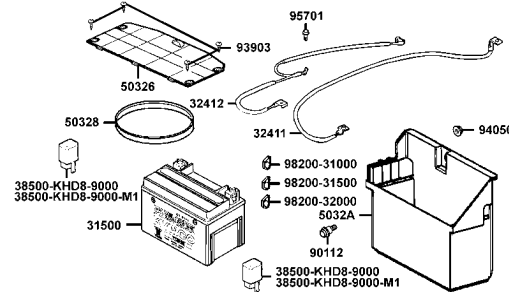

F12 車體蓋●行李箱
Body Cover●Luggage Box -89-

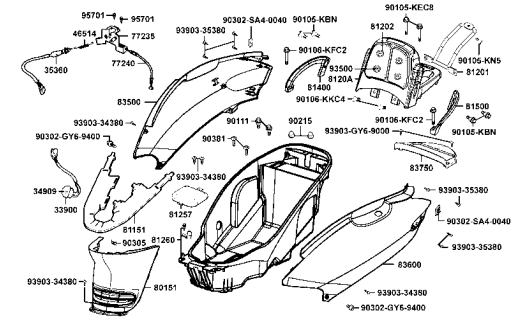

F13 空氣濾清器
Air Cleaner -93-

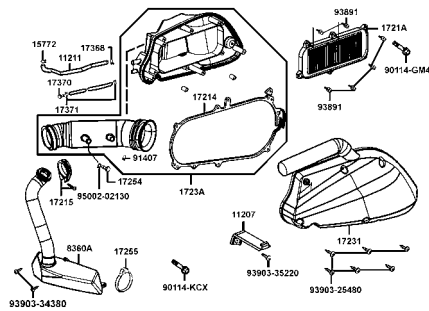

F14 排氣管
Exhaust Muffler -97-

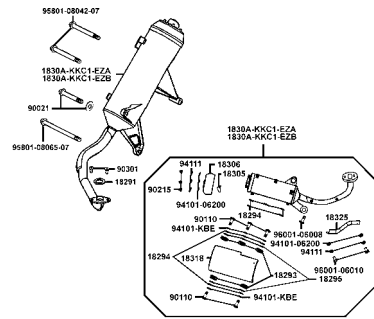

F15 腳架●起動踏桿
Stand●Kick Starter Arm -101-

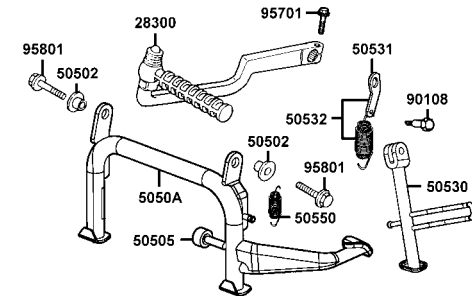

F16 後避震器
Rear Cushion -103-

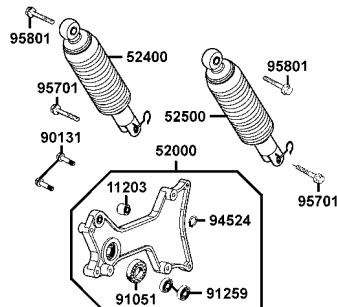

F17 前方向燈
Front Winker -105-

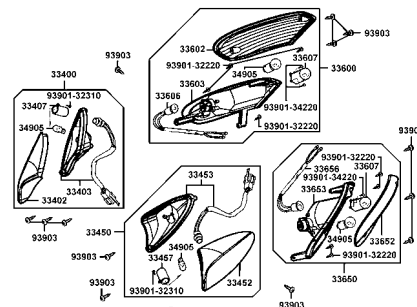

F18 後燈●後土除
Rear Light●Rear Fender -109-

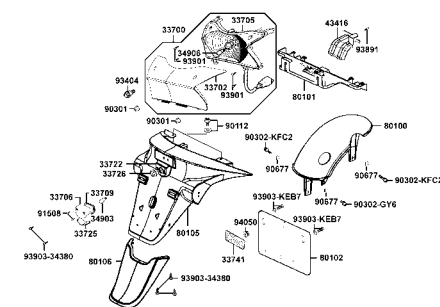

CONTENTS-FRAME GROUP

F19 主電路配線
Wire Harness

-113-

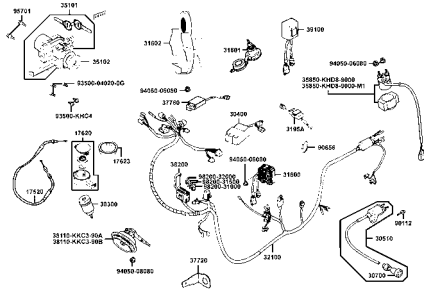

F20 車體
Frame Body

-117-

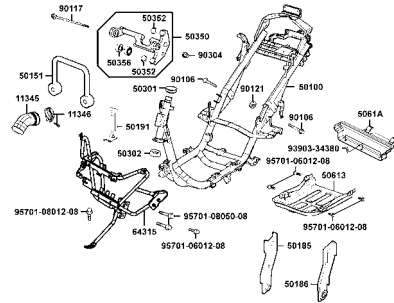

F21 水箱
Radiator

-121-

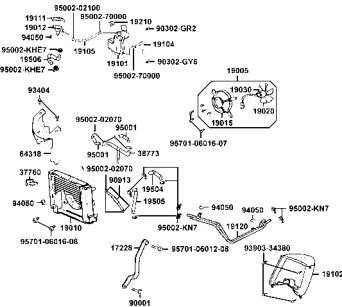

F22 前叉附件
Separated Parts Of Fr Fork

-125-

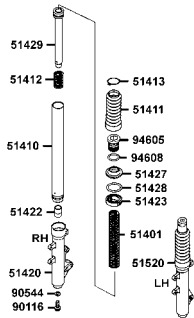

F23 二次空氣濾清器
Air Cleaner Two

-127-

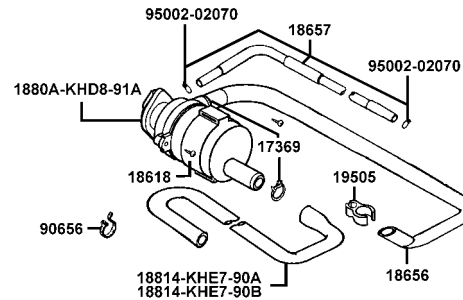

F24 注意標籤
Caution Label

-129-

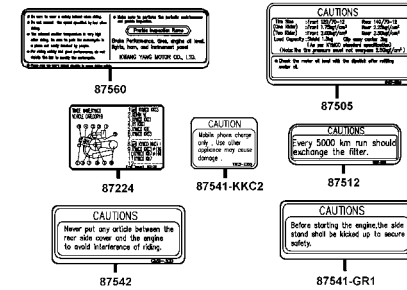

F25 標徽●貼紙
Emblem●Stripe

-131-



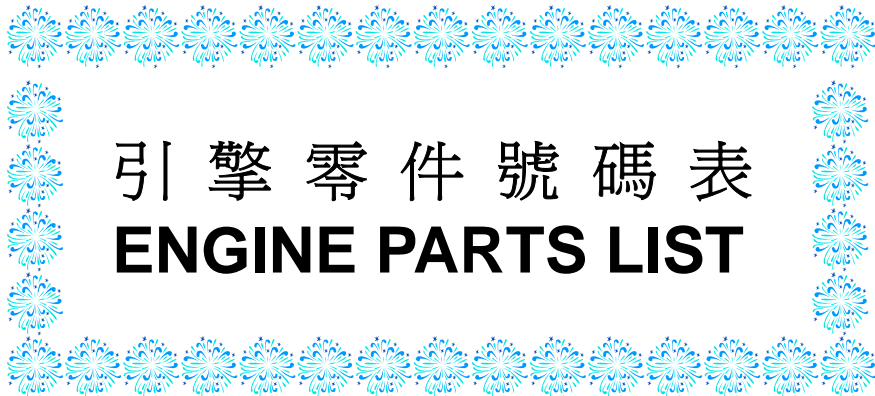

引擎零件號碼表
ENGINE PARTS LIST

E 1 Crank Case

曲
軸
箱

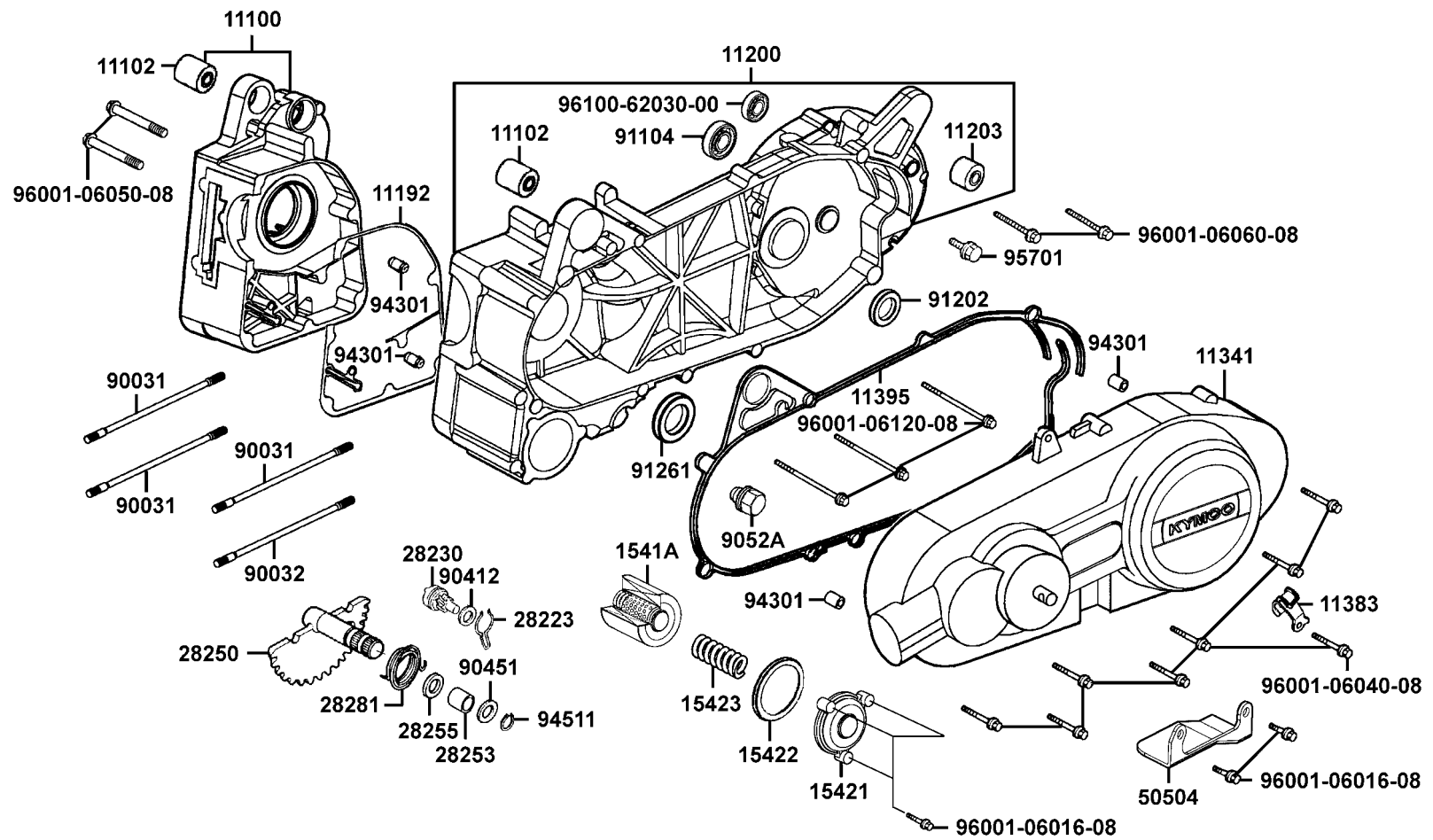

販賣記號 Sales mark	項目 Ref no	零件號碼 Part no	版數 Ver	英文名稱 Description	中文名稱 Chinese	需要用量 Regd no	參考價 Ref Price
		11100-KKC1-3050	1	CRANK CASE ASSY R	右曲軸箱組	1	
		11102-187-0030	3	RUB BUSH ENG HANGER	引擎吊架襯套	2	
		11192-KKC3-9000	0	GASKET CRANK CASE @	曲軸箱墊片	1	
		11200-KKC3-3150	0	CASE SET L CRANK	左曲軸箱	1	
		11203-GC7-3010	2	UNDER BUSH REAR CUSHION	後緩衝下襯套	1	
**		11341-KKC3-900	0	COVER L	左曲軸箱蓋	1	
		11383-KDU-9000	0	CLAMPER BRTH DRAIN TUBE	通氣管夾	1	
		11395-KKC3-9000	0	GASKET L COVER @	左曲軸箱蓋墊片 A	1	
		1541A-KKC3-9000	0	ELEMENT ASSY OIL FILTER	海綿濾清器油組	1	
		15421-KKC3-9000	0	CAP OIL FILTER	濾清器油蓋	1	
		15422-KKC3-9000	3	O RING 53.65*2.62	O環	1	
		15423-KKC3-9000	0	SPRING CAP OIL	油蓋彈簧	1	
		28223-KBN-9010	0	SPG KICK DRIVEN GEAR	起動惰齒輪彈簧	1	
		28230-KBN-9010	0	GEAR COMP KICK DRIVEN	起動惰齒輪	1	
		28250-KFC8-9000	0	SPINDLE COMP KICK STARTER	起動臂軸	1	
		28253-GN2-6020-M1	0	BUSH KICK SPINDLE	起動臂軸襯套	1	
		28255-GS6-0010	0	COLLAR KICK BOSS	套筒	1	
		28281-KKC2-9000	0	SPG KICK RETURN	起動彈簧	1	
		50504-KKC3-9000	2	STOPPER MAIN STAND	主腳架制止板	1	
		90031-KBE-9000	0	BOLT A STUD 8MM	雙頭螺絲 8MM	3	

E 1

E 1 Crank Case

曲
軸
箱

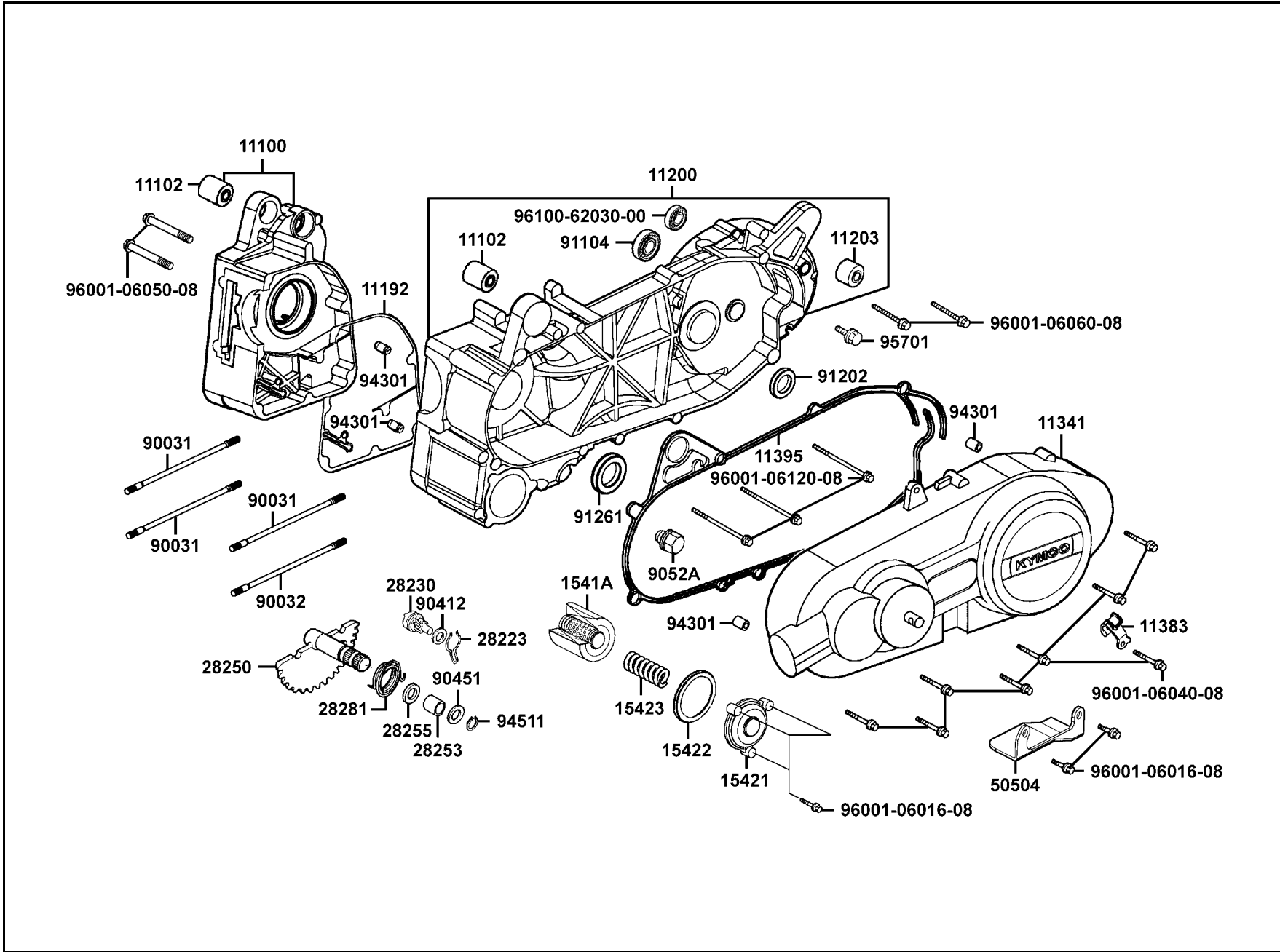

販賣記號 Sales mark	項目 Ref no	零件號碼 Part no	版數 Ver	英文名稱 Description	中文名稱 Chinese	需要用量 Regd no	參考價 Ref Price
		90032-KBE-9000	0	BOLT B STUD 8MM	雙頭螺絲 8MM	1	
		90412-329-0010	0	WASHER THRUST 10MM	華司 10MM	1	
		90451-GN2-6010	0	WASHER KICK SPINDLE	華司	1	
		9052A-GY6-9500	0	BOLT ASSY DRAIN PLUG	洩油螺絲	1	
		91104-KN7-6710	0	BRG BALL RADIAL 6204	軸承 6204	1	
		91202-KJ9-0040	0	OIL SEAL 20*32*6	油封 20X32X6	1	
		91261-415-0040	0	OIL SEAL 25*40*8	油封 25X40X8	1	
		94301-08140	0	DOWEL PIN 8*14	定位銷 8X14	4	
		94511-14000	0	CIR CLIP EX 14	外環夾 14MM	1	
		95701-08012-08	0	BOLT FLANGE 8*12	螺絲 8*12	1	
		96001-06016-08	0	BOLT FLANGE 6*16(C)	螺絲 6*16	5	
		96001-06040-08	0	BOLT FLANGE SH 6*40	螺絲 6X40	8	
		96001-06050-08	0	BOLT FLANGE SH 6*50	螺絲 6X50	2	
		96001-06060-08	0	BOLT FLANGE SH 6*60	螺絲 6X60	2	
		96001-06120-08	0	BOLT FLANGE SH 6*120	螺絲 6X120	3	
		96100-62030-00	0	BRG BALL RADIAL 6203	軸承 6203	1	

E 1

E 2 Cylinder Head Cover ● Cylinder Head

汽缸頭蓋 ● 汽缸頭

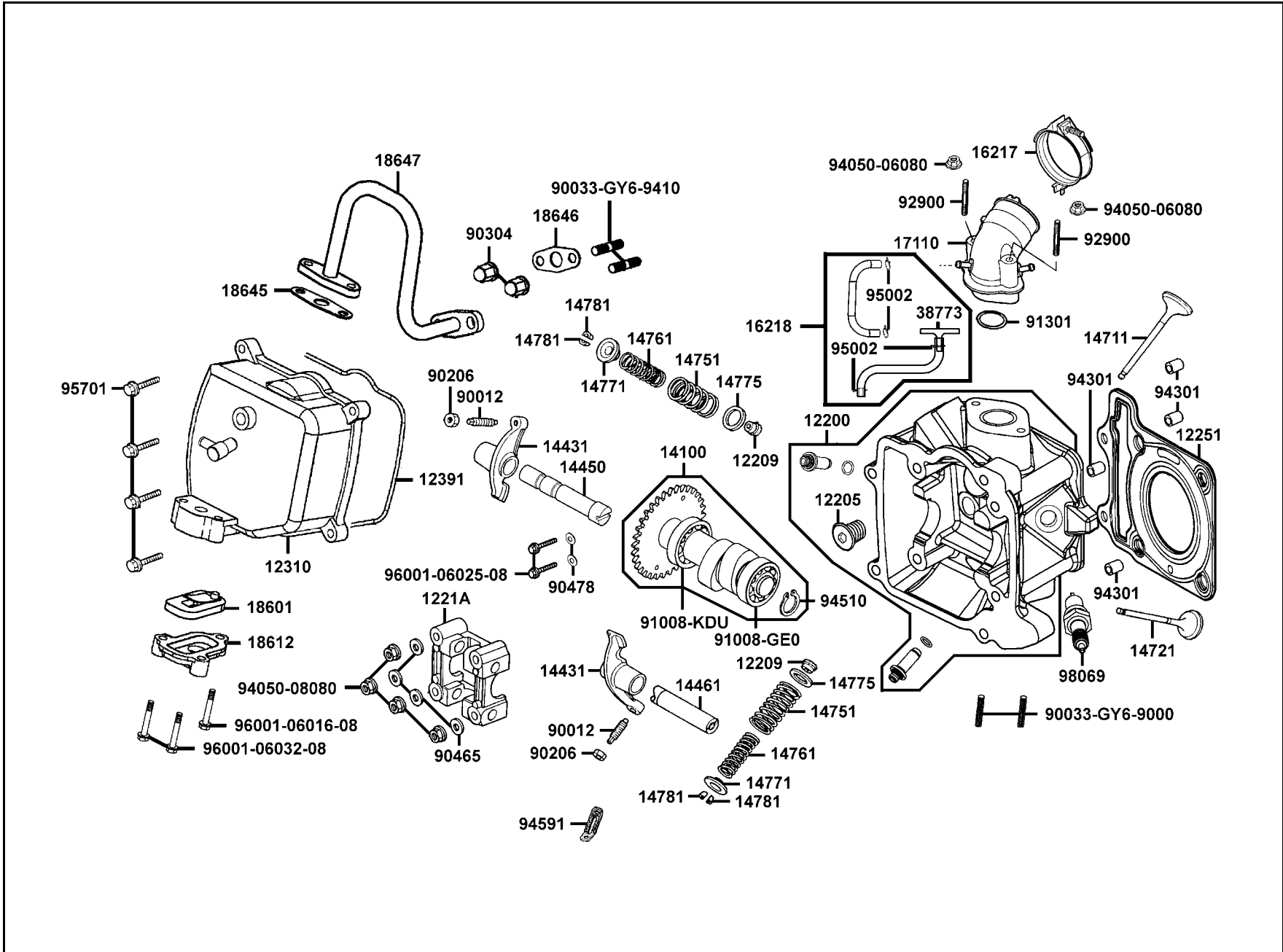

販賣記號 Sales mark	項目 Ref no	零件號碼 Part no	版數 Ver	英文名稱 Description	中文名稱 Chinese	需要用量 Regd no	參考價 Ref Price
		12200-KKC1-900	0	HEAD COMP CYLN	汽缸頭	1	
		12205-KE8-3010	0	BOLT SEALING 12MM	封閉螺栓	1	
		12209-GB4-6820-M1	0	SEAL VALVE STEM	門閥徑封	2	
		1221A-KBE-9000	1	HOLDER CAM SHAFT COMP	凸輪軸固定座	1	
		12251-KED1-9010	0	GASKET CYLINDER HEAD	汽缸頭墊片	1	
		12310-KBE-9000	4	COVER COMP CYLN HEAD	汽缸頭蓋	1	
		12391-KBE-9000	0	GASKET HEAD COVER	汽缸頭蓋墊圈	1	
		14100-KKC2-220	0	SHAFT COMP CAM	凸輪軸	1	
		14431-KKC1-9000	0	ARM VALVE ROCKER	門閥搖臂	2	
		14450-KBE-9000	0	SHAFT COMP IN ROCKER ARM	進氣閥搖臂軸	1	
		14461-KBE-9000	0	SHAFT EX ROCKER ARM	排氣閥搖臂軸	1	
		14711-KBE-9000	1	VALVE INLET	進氣門閥	1	
		14721-KAA-9000	3	VALVE EXHAUST	排氣門閥	1	
		14751-KJ9-0030	1	SPG VALVE OUTER	門閥外彈簧	2	
		14761-KJ9-0030	1	SPG VALVE INNER	門閥內彈簧	2	
		14771-GB4-6800	2	RETAINER VALVE SPRING	閥門彈簧保持器	2	
		14775-MA6-0000	0	SEAT VALVE SPG OUTER	門閥彈簧外座	2	
		14781-MA6-0000-M1	0	COTTER VALVE	閥門鎖扣	4	
		16217-KBE-9000	1	BAND INSULATOR	隔熱管夾	1	
		16218-KBE-E000	0	TUBE ASSY INLET PIPE CARB	通氣管	1	

E 2

E 2 Cylinder Head Cover ● Cylinder Head

汽缸頭蓋 ● 汽缸頭

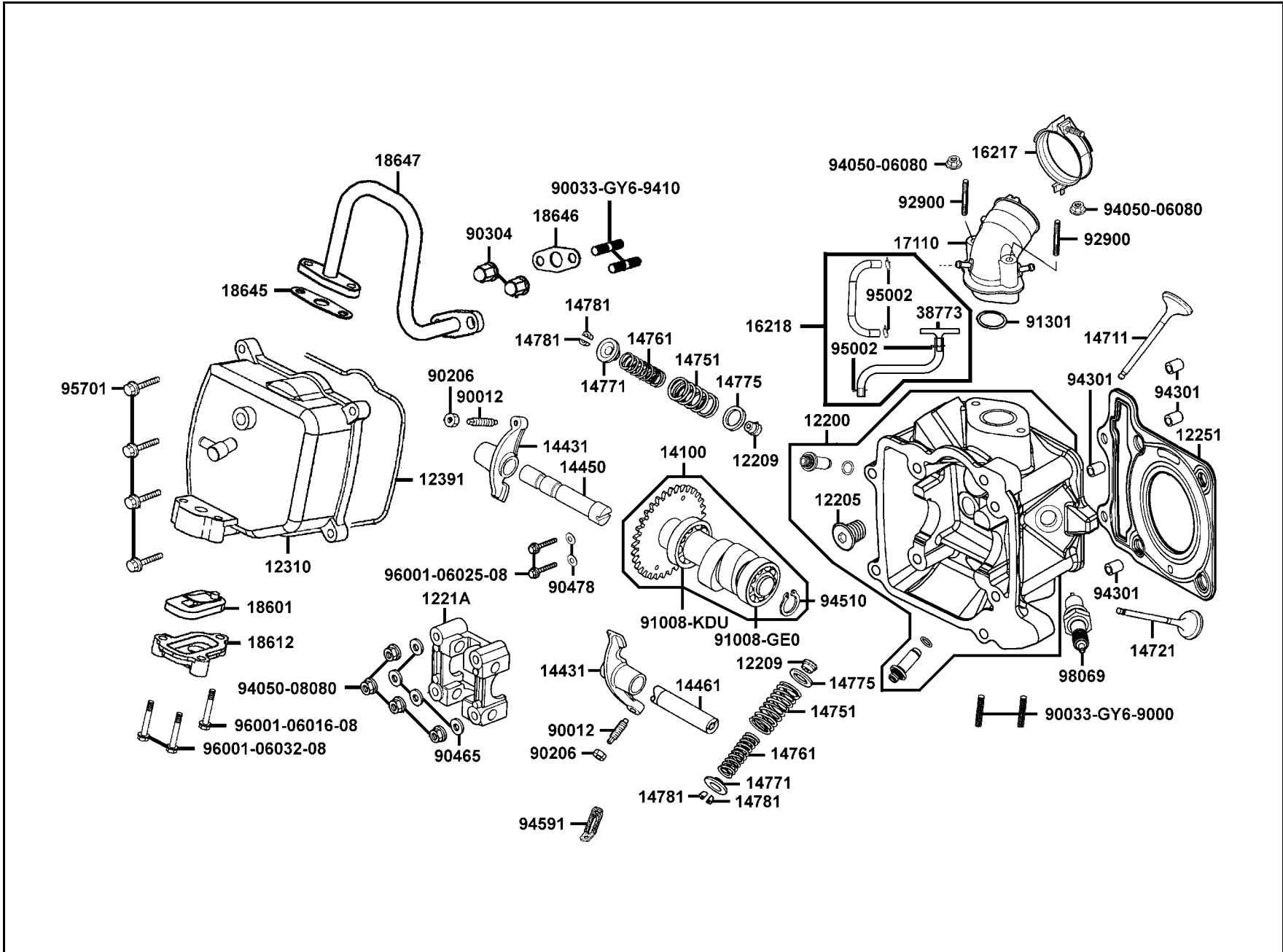

販賣記號 Sales mark	項目 Ref no	零件號碼 Part no	版數 Ver	英文名稱 Description	中文名稱 Chinese	需要用量 Regd no	參考價 Ref Price
		17110-KKC1-E000	0	PIPE COMP INLET	進氣管	1	
		18601-MJ1-7900	1	VALVE COMP REED (2ND)	閥片單向閥	1	
		18612-KBE-9000	0	COVER REED VALVE	單向閥護蓋	1	
		18645-GY6-9400	0	GASKET A/I PIPE	通氣鐵管墊片	1	
		18646-GY6-9400	0	GASKET A/I PIPE	通氣管墊片	1	
		18647-KBE-9000	0	PIPE COMP AIR	通氣鐵管	1	
		38773-PB9-0000	0	JOINT 3 WAY 3.5	三向管接頭	1	
		90012-333-0010	0	SCREW TAPPET ADJUSTING	樞軸調整螺絲	2	
		90033-GY6-9000	0	BOLT STUD 8*32	螺絲 8X32	2	
		90033-GY6-9410	0	BOLT STUD 6*16	特殊螺絲 6*16	2	
		90206-001-0010	0	NUT TAPPET ADJG	挺桿調整螺帽	2	
		90304-438-0000	2	NUT SPECIAL 6MM	螺帽 6MM	2	
		90465-MC4-0010	0	WASHER 8MM	華司 8MM	4	
		90478-700-0010	0	WASHER A 6MM	華司 6MM	2	
		91008-GE0-006	0	BRG BALL RADIAL 6002	軸承6002	1	
		91008-KDU-900	0	BRG BALL RADIAL TMB002JR2C3	軸承	1	
		91301-028-0010	0	O RING 27*2	O環 27X2.0	1	
		92900-06045-0B	0	BOLT STUD SH 6*45	雙頭螺絲 6*45	2	
		94050-06080	0	NUT FLANGE 6MM	螺帽	2	
		94050-08080	0	NUT FLANGE 8MM	螺帽 8MM	4	

E 2

E 2 Cylinder Head Cover ● Cylinder Head

汽缸頭蓋 ● 汽缸頭

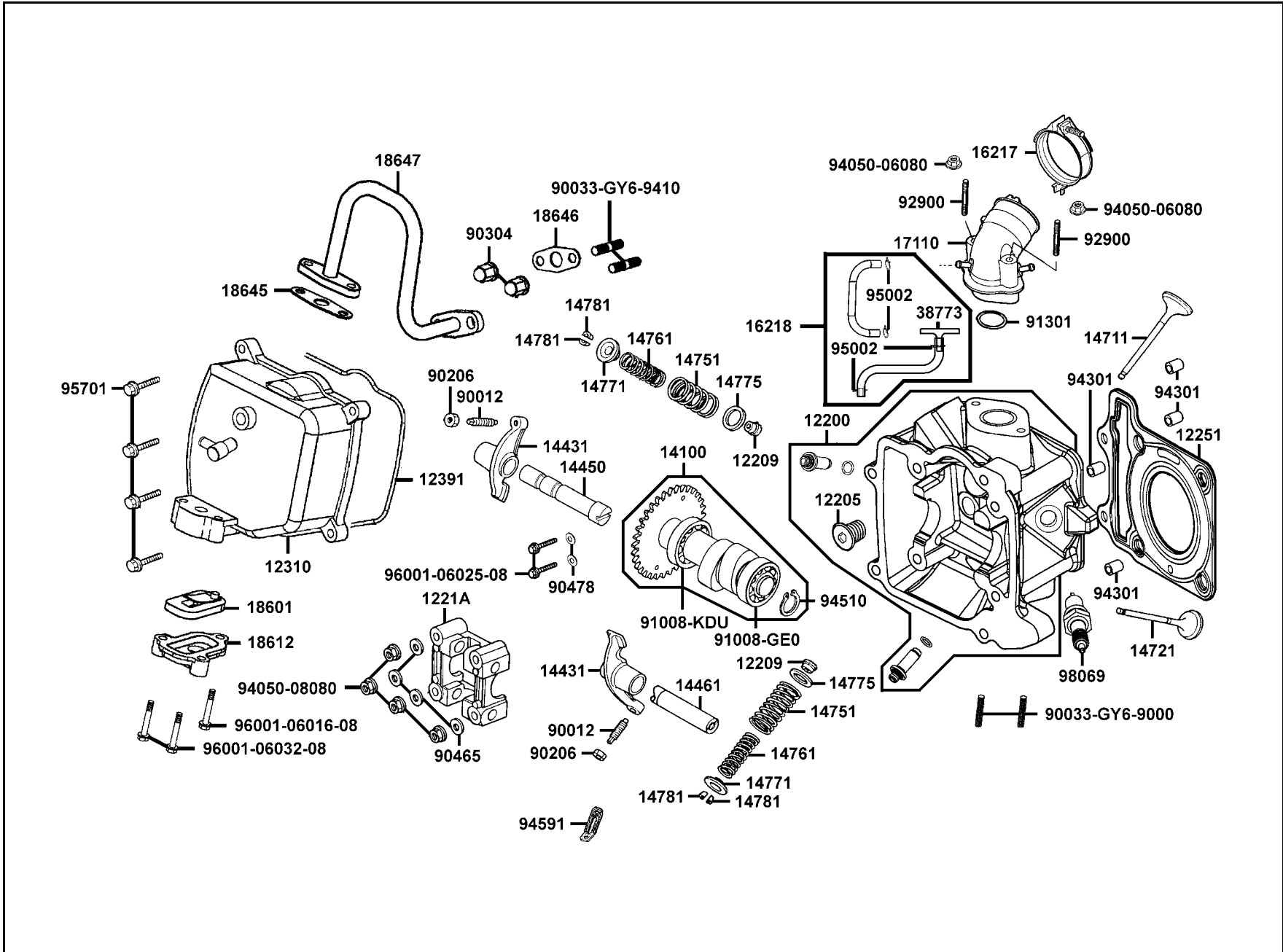

販賣記號 Sales mark	項目 Ref no	零件號碼 Part no	版數 Ver	英文名稱 Description	中文名稱 Chinese	需要用量 Regd no	參考價 Ref Price
		94301-10160	0	DOWEL PIN 10*16	定位銷 10X16	4	
		94510-15000	0	CIR CLIP EX 15	環夾	1	
		94591-KBF-9000	0	CLIP 2*71	油管夾	1	
		95002-02070	0	CLIP B7 TUBE	管夾	4	
		95701-06025-08	0	BOLT FLANGE 6*25	螺絲 6X25	4	
		96001-06016-08	0	BOLT FLANGE 6*16	螺絲 6*16	1	
		96001-06025-08	0	BOLT FLANGE 6*25	螺絲 6X25	2	
		96001-06032-08	0	BOLT FLANGE 6*32	螺絲 6*32	2	
		98069-5791R-00	0	SPARK PLUG DPR(7EA-9)	火星塞	1	

E 2

E 3 Cylinder●Piston●Crankshaft

汽缸
●
活塞
●
曲軸

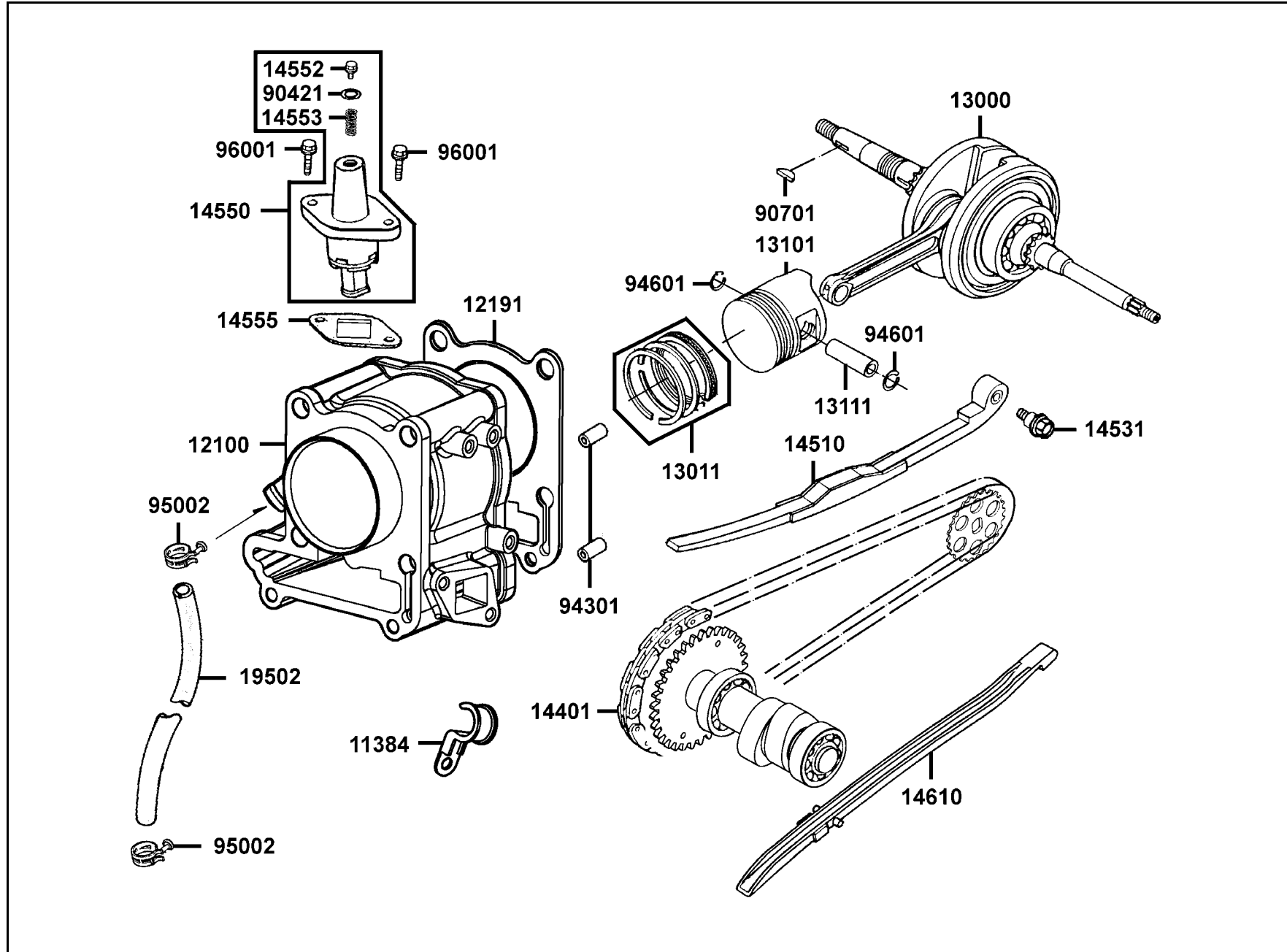

販賣記號 Sales mark	項目 Ref no	零件號碼 Part no	版數 Ver	英文名稱 Description	中文名稱 Chinese	需要用量 Regd no	參考價 Ref Price
		11384-KHE7-9000	1	CLAMPER A RR BRK HOSE	後煞車油管夾 A	1	
		12100-KKC1-9000	0	CYLINDER COMP	汽缸	1	
		12191-KKC3-9000	0	GASKET CYLINDER	汽缸墊片	1	
		13000-KKC2-900	2	CRANK SHAFT COMP	曲軸	1	
		13011-GY6-9000	0	RING SET PISTON	活塞環	1	
		13101-KED1-9000	0	PISTON	活塞	1	
		13111-384-0010	1	PIN PISTON	活塞銷	1	
		14401-KDU-9000	0	CHAIN CAM	凸輪軸驅動鏈條	1	
		14510-KBE-9000	1	TENSIONER CAM CHAIN	凸輪軸鏈條張力桿	1	
		14531-KJ9-0010	0	PIVOT CAM CHAIN TENSIONER	張力桿螺栓	1	
		14550-KS4-0040-M2	0	ADJUSTER CAM CHAIN	鏈條張力調節器	1	
		14552-KS4-0030	0	PLUG ADJUSTER	調整插頭	1	
		14553-KS4-0030	0	SPRING CAM CHAIN ADJUSTER	調整彈簧	1	
		14555-KJ9-0010	0	GASKET CAM CHAIN ADJUSTER	調整器墊片	1	
		14610-KJ9-0010	0	GUIDE COMP CAM CHAIN	鏈條導桿	1	
		19502-KBE-9000	0	HOSE WATER B	水管	1	
		90421-KM1-0030	0	WASHER SEALING 8*16*1.6	華司 8X16X1.6	1	
		90701-HB6-0110	0	KEY WOODRUFF 25*14*4	固定鍵 25X14X4	1	
		94301-10160	0	DOWEL PIN 10*16	定位銷 10X16	2	
		94601-15000-M1	0	CLIP PISTON PIN 15MM	活塞銷環夾 15MM	2	

E 3

E 3 Cylinder●Piston●Crankshaft

汽缸
●
活 塞
●
曲 軸

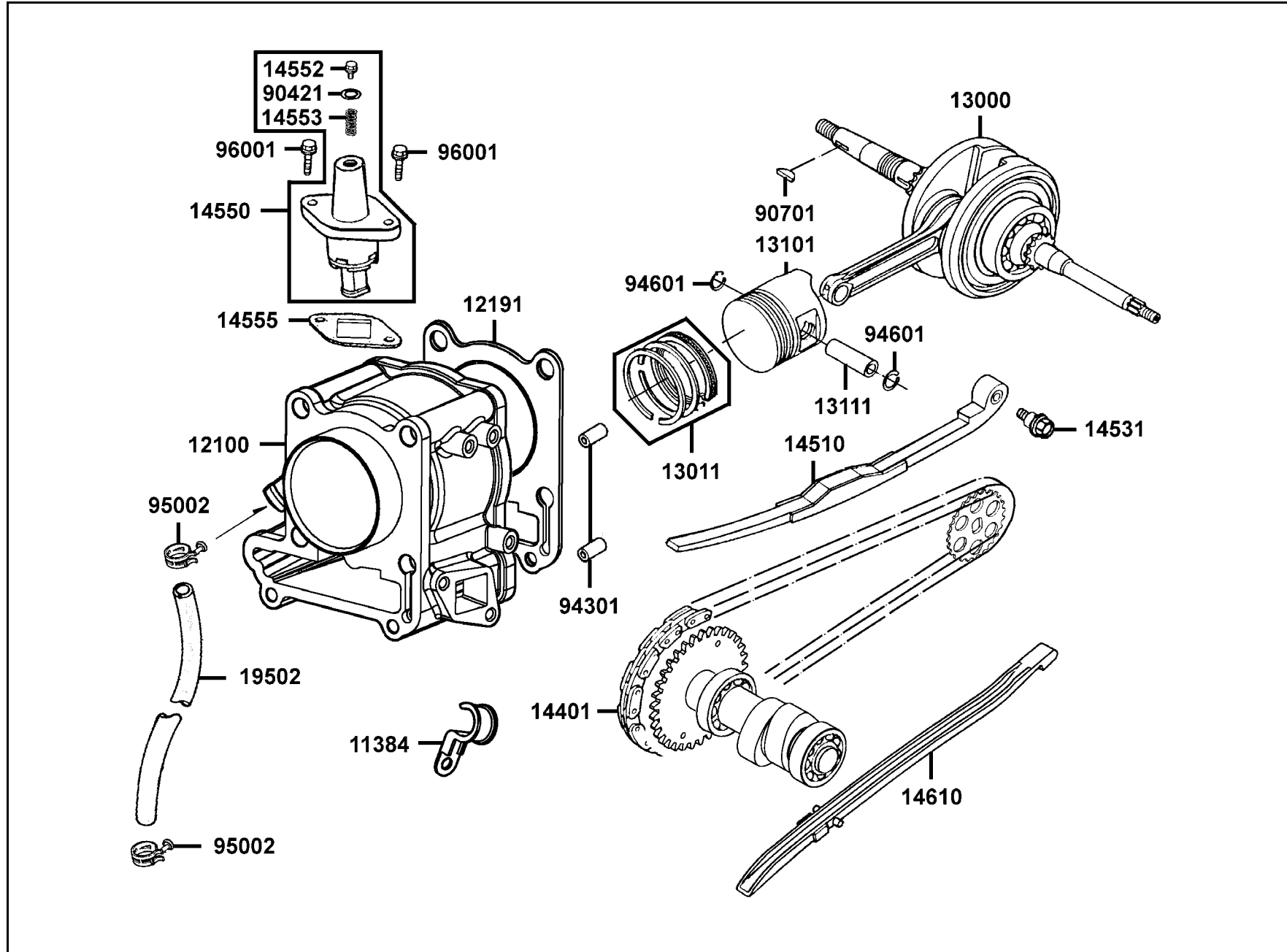

販賣記號 Sales mark	項目 Ref no	零件號碼 Part no	版數 Ver	英文名稱 Description	中文名稱 Chinese	需要用量 Regd no	參考價 Ref Price
		95002-KN7-9100	1	CLIP TUBE	管夾	2	
		96001-06018-08	0	BOLT FLANGE SH 6*18	螺絲 6X18	2	

E 4 Right Crankcase Cover

右
曲
軸
箱
蓋

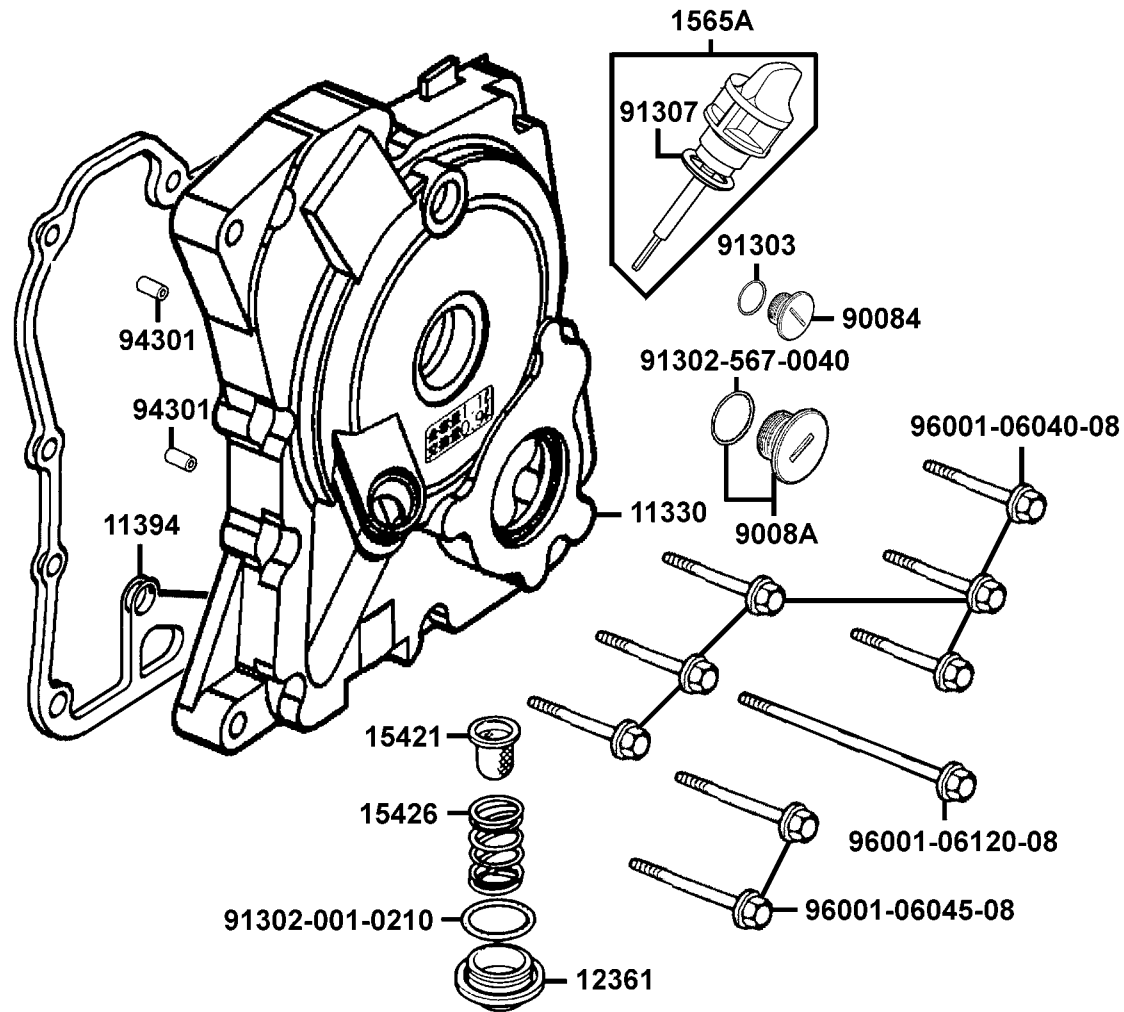

販賣記號 Sales mark	項目 Ref no	零件號碼 Part no	版數 Ver	英文名稱 Description	中文名稱 Chinese	需要用量 Regd no	參考價 Ref Price
		11330-KKC3-900	2	COVER COMP RIGHT	右曲軸箱蓋	1	
		11394-KBE-9000	0	GASKET R COVER @	右曲軸箱蓋墊片 @	1	
		12361-GY6-9010	0	HOLE CAP TAPPET ADJUSTING	調節螺帽	1	
		15421-107-0000	1	SCREEN OIL FILTER	濾油網	1	
		15426-GE1-9200	0	SPG OIL FILTER SCREEN	濾油網彈簧	1	
		1565A-KBE-9000	0	GAUGE OIL LEVEL ASSY	機油尺組	1	
		90084-428-0010	0	CAP A.C.G	A.C.G.蓋	1	
		9008A-KE2-9000	0	CAP ASSY 30MM	蓋組	1	
		91302-001-0210	0	O-RING 30.8M/M	O環 30.8MM	1	
		91302-567-0040	0	O-RING 27.4*2.4	O環 27.4X2.4	1	
		91303-377-0010	0	O-RING 13.8*2.5	O環 13.8X2.5	1	
		91307-035-0010	0	O RING 18*3	O環 18X3	1	
		94301-08140	0	DOWEL PIN 8*14	定位銷 8X14	2	
		96001-06040-08	0	BOLT FLANGE SH 6*40	螺絲 6X40	6	
		96001-06045-08	0	BOLT FLANGE SH 6*45	螺絲 6X45	2	
		96001-06120-08	0	BOLT FLANGE SH 6*120	螺絲 6X120	1	

E 4

E 5 Transmission

傳動系

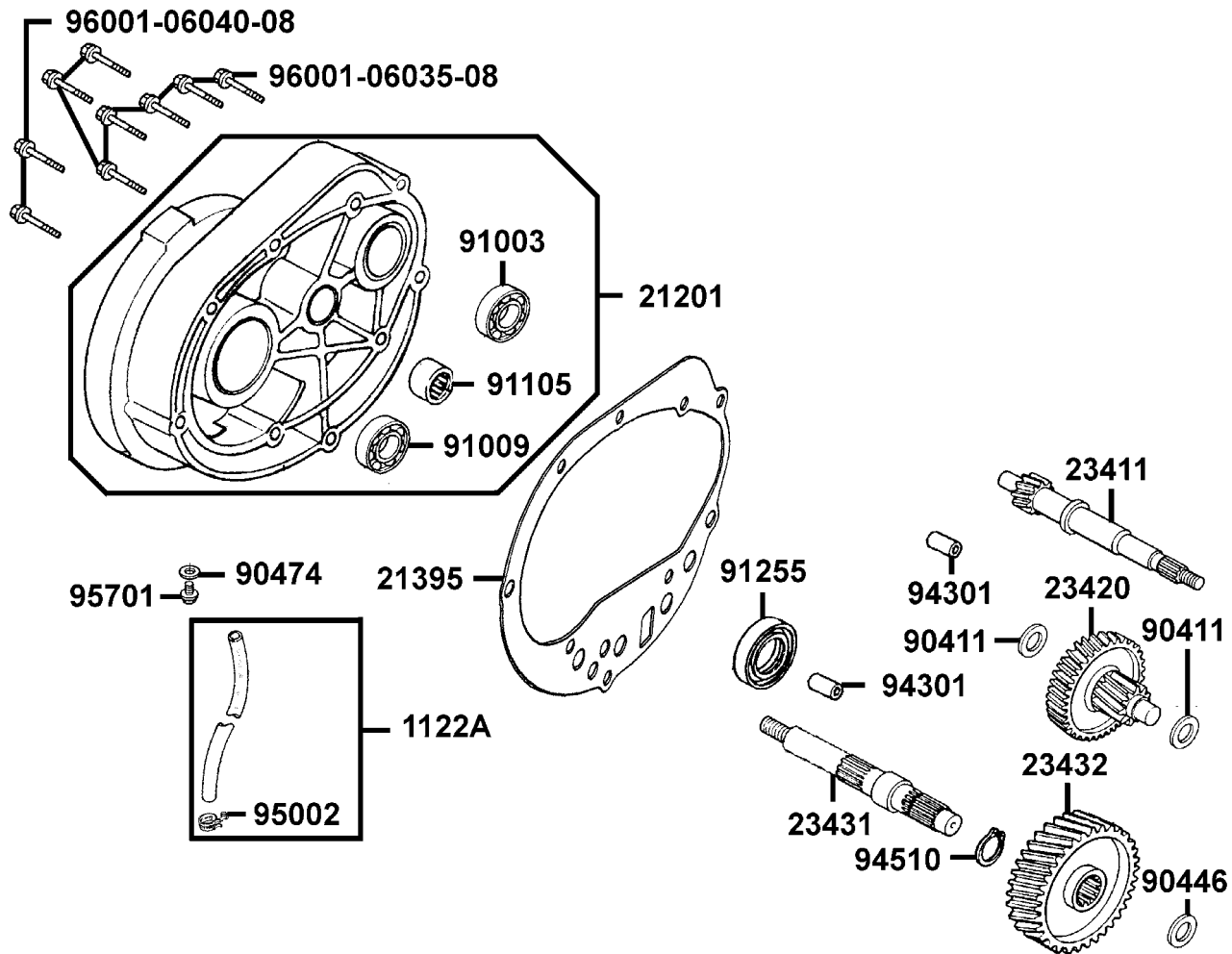

販賣記號 Sales mark	項目 Ref no	零件號碼 Part no	版數 Ver	英文名稱 Description	中文名稱 Chinese	需要用量 Regd no	參考價 Ref Price
		1122A-KKC2-9000	0	TUBE ASSY	通氣管	1	
		21201-KFC8-3050	0	CASE SET MISSION	主軸箱組	1	
		21395-KFC8-9000	0	GASKET MISSION CASE @	主軸蓋墊片	1	
		23411-KKC3-900	2	SHAFT DRIVE	驅動軸	1	
		23420-KFC8-900	2	SHAFT COMP COUNTER	副軸組	1	
		23431-KFC8-9000	0	SHAFT FINAL	最終軸	1	
		23432-KFC8-900	2	GEAR FINAL	最終齒輪	1	
		90411-KM1-0010	0	WASHER THRUST 14*32*1	華司 14X32X1	2	
		90446-357-0010	0	WASHER THRUST 17.2MM	華司 17.2MM	1	
		90474-333-0010	0	WASHER 8MM	華司 8MM	1	
		91003-KS4-004	0	BRG BALL RADIAL 6301TMB	軸承 6301	1	
		91009-GE0-0040	0	BRG BALL RADIAL 6004 UU	軸承 6004	1	
		91105-KN7-6720-Y1	0	BRG NEEDLE	滾針軸承	1	
		91255-GE0-0060	0	OIL SEAL 27*42*7	油封 27X42X7	1	
		94301-08140	0	DOWEL PIN 8*14	定位銷 8X14	2	
		94510-20000	0	CIR CLIP EXTERNAL 20MM	外環夾 20MM	1	
		95002-02080	0	CLIP B8 TUBE	管夾	1	
		95701-08012-08	0	BOLT FLANGE 8*12	螺絲 8X12	1	
		96001-06035-08	0	BOLT FLANGE SH 6*35	螺絲 6X35	7	
		96001-06040-08	0	BOLT FLANGE SH 6*40	螺絲 6X40	2	

E 6 Driven Pulley

傳動皮帶輪

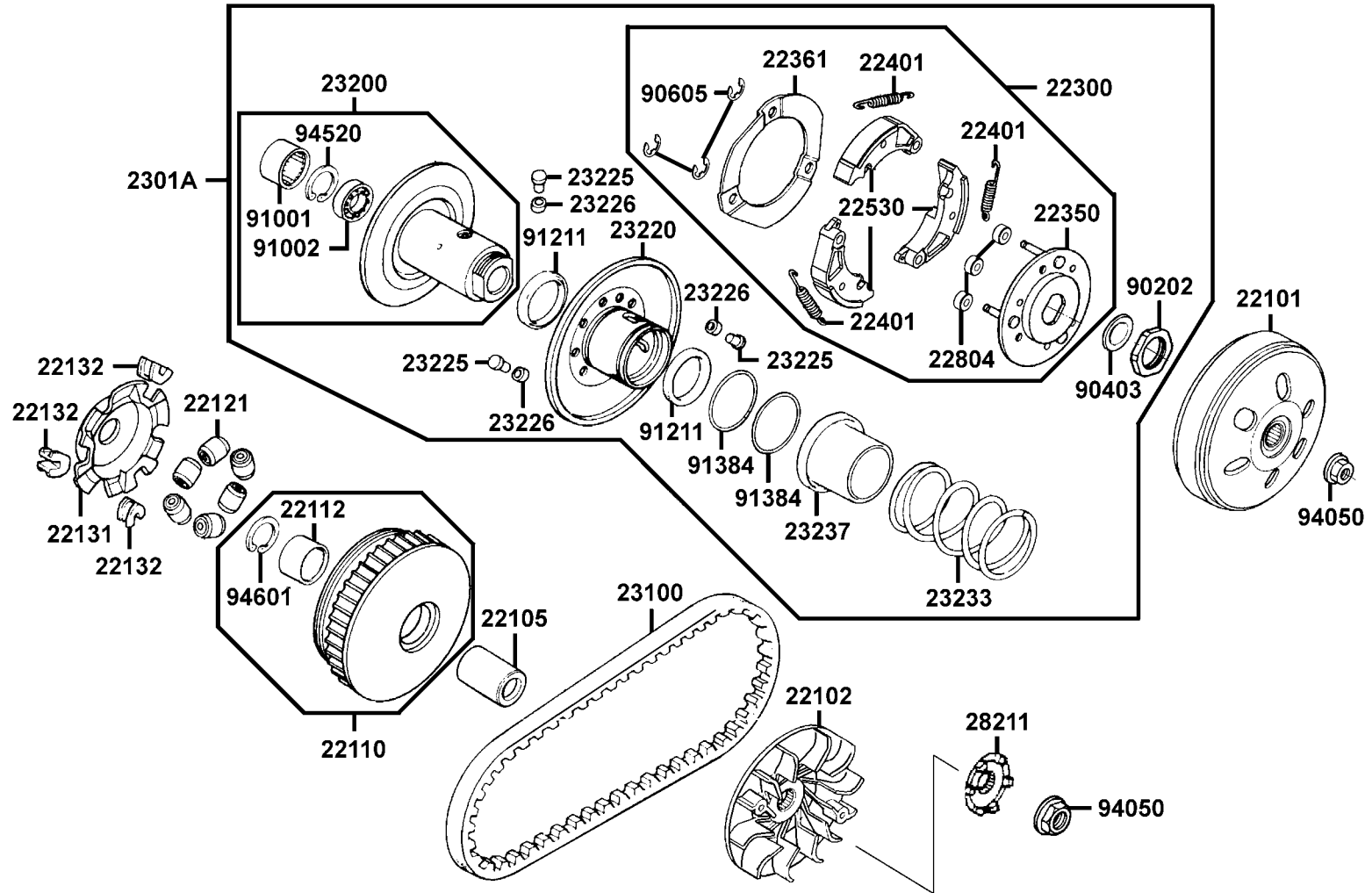

販賣記號 Sales mark	項目 Ref no	零件號碼 Part no	版數 Ver	英文名稱 Description	中文名稱 Chinese	需要用量 Regd no	參考價 Ref Price
		22101-KBE-9000	0	OUTER CLUTCH	離合器外套	1	
		22102-KKC3-9000	0	FACE DRIVE	驅動皮帶扇葉盤	1	
		22105-KHD4-E00	1	BOSS DRIVE FACE	襯套	1	
		22110-KKC3-9000	0	FACE COMP MOVABLE DRIVE	滑動式驅動盤組	1	
		22112-KAA-9000-H1	0	COLLAR DRIVE FACE	套筒	1	
		22121-KED1-9000	1	ROLLER COMP WEIGHT	配重滾子	6	
		22131-KAA-9000	1	PLATE RAMP	斜板	1	
		22132-KN7-6700	3	PIECE SLIDE	斜板邊件	3	
		22300-KN7-6710	2	PLATE ASSY DRIVE	驅動板組	1	
		22350-KN7-6700	0	PLATE COMP DRIVE	驅動板	1	
		22361-KN7-6710	0	PLATE CLUTCH SIDE	離合器舉升板	1	
		22401-KN7-6710	0	SPRING CLUTCH	離合器彈簧	3	
		22530-KN7-6710	2	WEIGHT CLUTCH	離合器配重	3	
		22804-GB2-0010	0	RUBBER CLUTCH DUMPER	橡皮	3	
		2301A-KBE-9000	4	PULLEY SUB ASSY	從動皮帶輪組	1	
		23100-KN7-6720-M1	0	BELT DRIVE	從動皮帶	1	
		23200-KBE-9000	0	FACE ASSY DRIVEN	平面轉動組	1	
		23220-KN7-6710	0	FACE COMP MOVABLE DRIVEN	滑動式從動皮帶輪	1	
		23225-GC8-0040	0	PIN ROLLER GUIDE	滾導銷	3	
		23226-GC8-0040	0	ROLLER GUIDE	滾子	3	

E 6 Driven Pulley

傳動皮帶輪

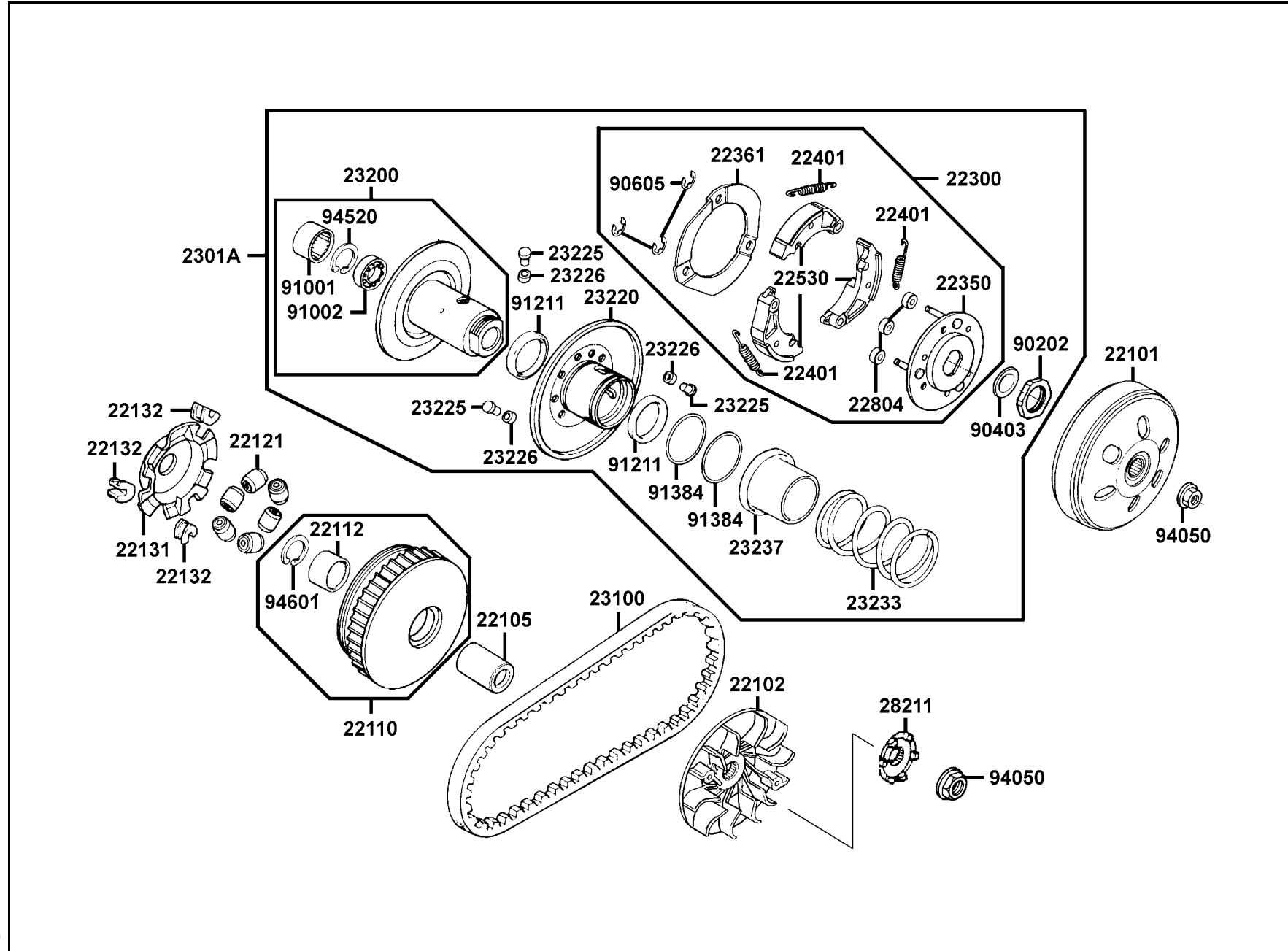

販賣記號 Sales mark	項目 Ref no	零件號碼 Part no	版數 Ver	英文名稱 Description	中文名稱 Chinese	需要用量 Regd no	參考價 Ref Price
		23233-KN7-6710	0	SPG DRIVEN FACE	驅動彈簧	1	
		23237-KG8-9010	0	COLLAR SEAL	套筒	1	
		28211-KFC8-9000	0	RATCHET KICK STARTER	起動齒盤	1	
		90202-KN7-6710	0	NUT SPECIAL 28MM	螺帽 28MM	1	
		90403-KN7-6710	0	WASHER THTUST 28*44*1.5	華司28*44*1.5	1	
		90605-166-7210	0	CIR CLIP 7MM	環夾 7MM	3	
		91001-GY6-90A	0	BRG NDL 20*29*18	軸承 20X29X18	1	
		91002-GA7-70A	0	BRG BALL RADIAL 6902U	軸承 6902U	1	
		91211-KBE-9000	0	SEAL DRIVEN FACE 34*41*4	驅動油封 34X41X4	2	
		91384-KBE-9000	0	O-RING	O環	2	
		94050-12080	0	NUT C FLANGE 12MM	螺帽 12MM	2	
		94520-28000	0	CIR CLIP IN 28	內環夾 28MM	1	
		94601-33000	0	CLIP PISTON PIN 33MM	環夾	1	

E 7 Starting Motor ● Oil Pump

起
動
馬
達
●
機
油
泵

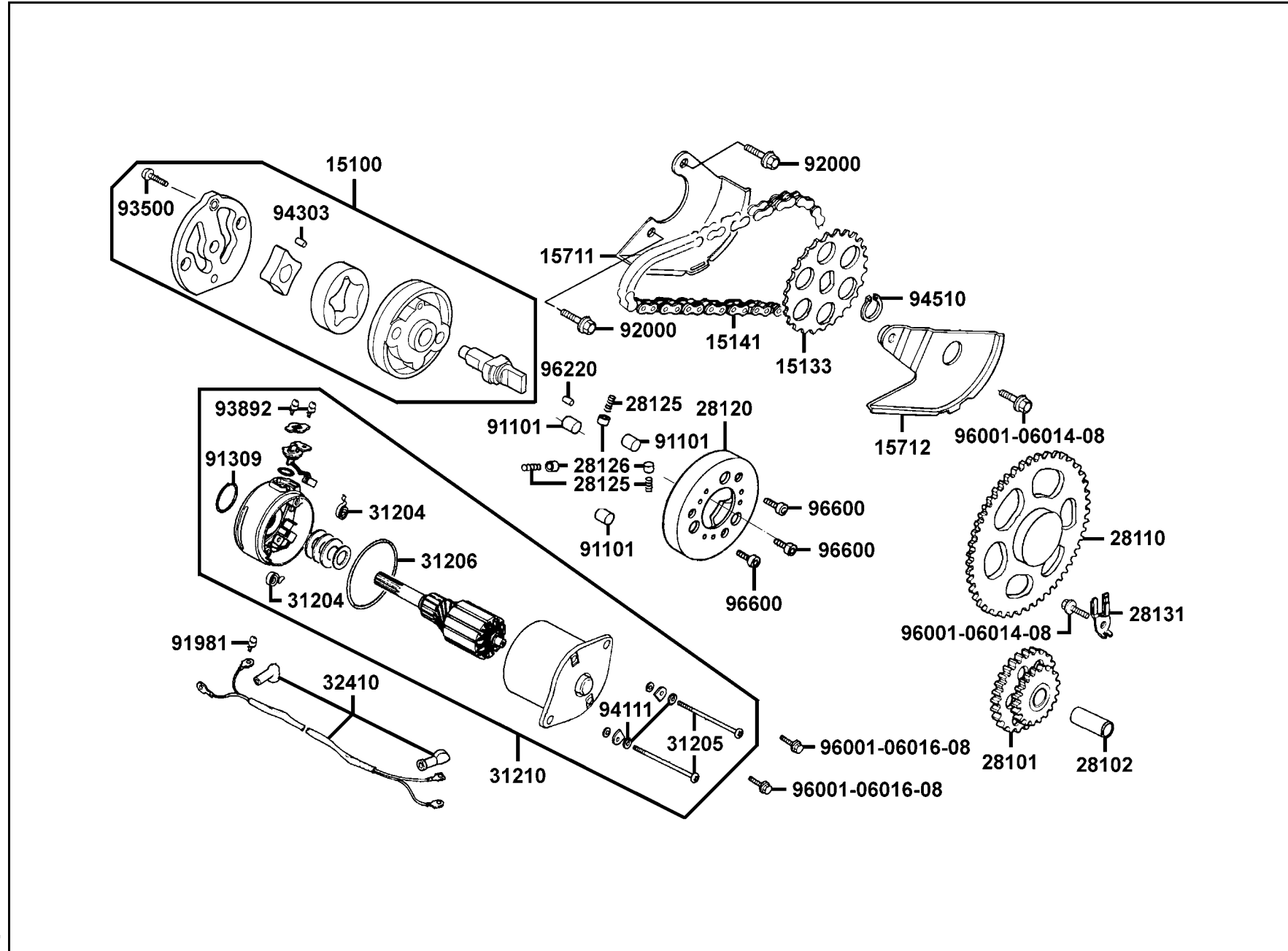

販賣記號 Sales mark	項目 Ref no	零件號碼 Part no	版數 Ver	英文名稱 Description	中文名稱 Chinese	需要用量 Regd no	參考價 Ref Price
		15100-KKC3-9000	0	PUMP ASSY OIL	油泵	1	
		15133-KM1-0010	0	SPROCKET OIL PUMP DRIVE	機油泵驅動齒輪	1	
		15141-KJ9-0040	0	CHAIN OIL PUMP	機油泵驅動鏈條	1	
		15711-KKC3-9000	0	OIL SEPARATER A	機油分隔板 A	1	
		15712-KBE-9000	0	OIL SEPARATER COMP B	機油分隔板 B	1	
		28101-KJ9-0110	0	GEAR STARTER REDUCTION	起動減速齒輪	1	
		28102-KJ9-0010	0	SHAFT STARTER REDUCTION GEAR	起動減速齒輪軸	1	
		28110-KN7-6720	0	GEAR COMP STARTING CLUTCH	起動齒輪	1	
		28120-KBE-305	0	OUTER COMP STARTING CLUTCH	離合器外套	1	
		28125-426-0010	0	SPRING ROLLER STARTER CLUTCH	離合器滾子彈簧	3	
		28126-KDU-900	0	CAP STARTING ROLLER SPRING	滾子彈簧蓋	3	
		28131-KN7-6710	0	GUIDE STARTING DRIVEN GEAR	起動齒輪導片	1	
		31204-KN7-6700	0	SPG CARBON BRUSH	碳刷彈簧	2	
		31205-KN7-6700	0	BOLT SET	螺絲	2	
		31206-KN7-6700	0	O-RING	O環	1	
		31210-KKC3-9000	0	MOTOR UNIT START	起動馬達組	1	
		32410-KKC3-9000	0	CABLE START MOTOR	起動馬達接地線	1	
		91101-179-7110-M1	0	ROLLER 10*10	滾子 10X10	3	
		91309-425-0040	0	O-RING 24.4*3.1	O環 24.4X3.1	1	
		91981-KN7-6700	0	SCREW WASH 5X8	螺絲 5X8	1	

E 7 Starting Motor ● Oil Pump

起動馬達 ● 發電泵

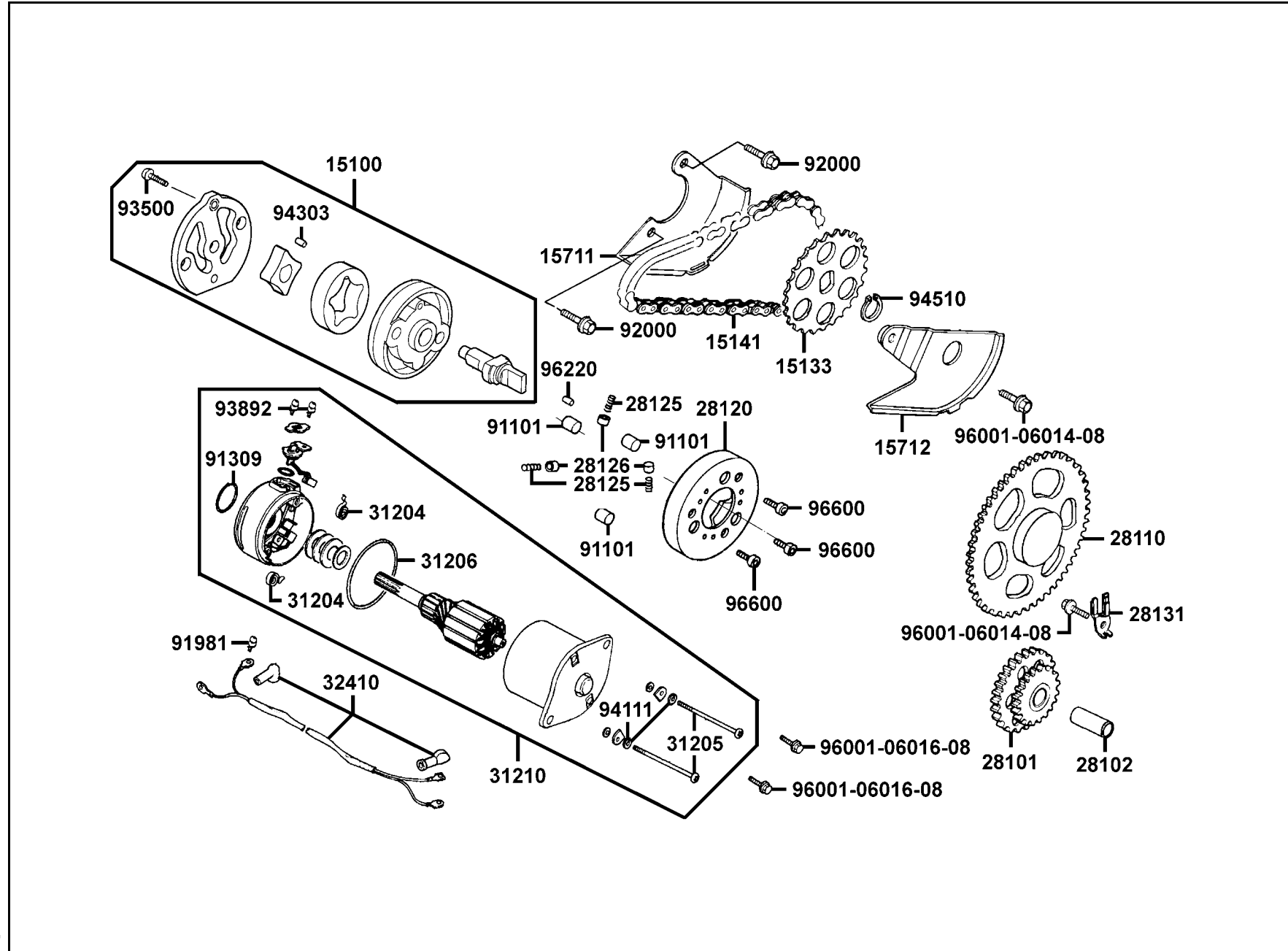

販賣記號 Sales mark	項目 Ref no	零件號碼 Part no	版數 Ver	英文名稱 Description	中文名稱 Chinese	需要用量 Regd no	參考價 Ref Price
		92000-06028-0H	0	BOLT FLANGE SH 6*28	螺絲 6X28	2	
		93500-03010-1A	0	SCREW PAN 3*10	螺絲 3*10	1	
		93892-04006-08	0	SCREW WASH 4*6	螺絲 4*6	2	
		94111-05800	0	WASHER SPRING 5MM	華司 5MM	2	
		94303-04065	0	PIN DOWEL 4*65	定位銷4*65	1	
		94510-10000	0	CIR CLIP EX 10MM	外環夾 10MM	1	
		96001-06014-08	0	BOLT FLANGE SH 6*14	螺絲 6X14	2	
		96001-06016-08	0	BOLT FLANGE SH 6*16	螺絲 6X16	2	
		96220-60100	0	ROLLER 6*10	定位銷 6X10	1	
		96600-08015-10	1	SOCKET BOLT 8*15	螺絲 8X15	3	

販賣記號 Sales mark	項目 Ref no	零件號碼 Part no	版數 Ver	英文名稱 Description	中文名稱 Chinese	需要用量 Regd no	參考價 Ref Price
		19211-KKC3-9000	0	BODY WATER PUMP	水泵本體	1	
		19215-KJ9-0110	0	IMPELLER WATER PUMP	水泵葉輪	1	
		19217-657-0240	0	SEAL MECHANICAL	機械油封	1	
		19221-KKC3-9000	0	COVER WATER PUMP	水泵蓋	1	
		19229-KKC3-900	0	GASKET WATER PUMP	水泵墊片	1	
		19231-KBE-9000	2	SHAFT WATER PUMP	水泵樞軸	1	
		19300-KE1-0030-M1	1	THERMOSTAT ASSY	恆溫器	1	
		19310-KBE-9000	0	CASE COMP THERMOSTAT	恆溫器室	1	
		19315-KBE-9000	2	COVER THERMOSTAT	恆溫器蓋	1	
		19501-KKC3-9000	0	HOSE WATER A	冷卻水管 A	1	
		19503-KBE-9000	0	HOSE C WATER	冷卻水管	1	
		30300-KBE-9000	2	GEN ASSY PULSE	脈動線圈	1	
		30301-KBE-9000-M2	0	GEN ASSY PULSE	脈動線圈	1	
		31110-KBE-9000	2	FLYWHEEL COMP	飛輪	1	
		31110-KBE-9000-M2	0	FLYWHEEL COMP	飛輪	1	
		31120-KBE-900	4	STATOR COMP	轉子線圈	1	
		31120-KBE-90B	3	STATOR COMP	轉子線圈	1	
		32101-KHD8-9000	1	SUBCORD	配線	1	
		37750-PC1-0050	0	THERMO UNIT ASSY	自動控溫器	1	
		90201-KR8-7520-M1	0	NUT FLANGE 14MM	螺帽14MM	1	

販賣記號 Sales mark	項目 Ref no	零件號碼 Part no	版數 Ver	英文名稱 Description	中文名稱 Chinese	需要用量 Regd no	參考價 Ref Price
		90401-KJ9-0010	0	WASHER THRUST 14*28*2	華司 14X28X2	1	
		90423-KJ9-0010	0	WASHER 7.2*13*1.2	華司 7.2X13X1.2	1	
		90478-700-0010	0	WASHER 6MM	華司 6MM	1	
		91001-KJ9-006	0	BRG BALL RADIAL 6901	軸承 6901	1	
		91201-KJ9-0040	0	OIL SEAL 12*20*4	油封 12X20X4	1	
		91301-KV7-6710	0	O-RING 14.8*1.9	O環 14.8X1.9	1	
		91302-567-0040	0	O-RING 27.4*2.4	O環 27.4X2.4	1	
		92000-05032-0H	0	BOLT HEX 5*32	螺絲 5X32	3	
		93500-05016-0H	0	SCREW PAN 5*16	螺絲 5X16	4	
		94301-08140	0	DOWEL PIN 8*14	定位銷 8X14	2	
		94520-26000	0	CIR CLIP INTERAL 26MM	內環夾 26MM	1	
		94591-KBF-9000	0	CLIP 2*71	環夾	1	
		95002-KN7-9100	1	CLIP TUBE	水管夾	4	
		96001-06010-08	0	BOLT FLANGE SH 6X10	螺絲 6X10	1	
		96001-06018-08	0	BOLT FLANGE SH 6*18	螺絲 6X18	1	
		96001-06020-08	0	BOLT FLANGE SH 6*20	螺絲 6X20	3	
		96001-06022-08	0	BOLT FLANGE SH 6*22	螺絲 6X22	2	
		96001-06028-02	0	BOLT FLANGE SH 6*28	螺絲 6X28	2	
		96100-60000-00	0	BEARING BALL RADIAL 6000	軸承 6000	1	

E 8

E 9 Carburetor

化油器

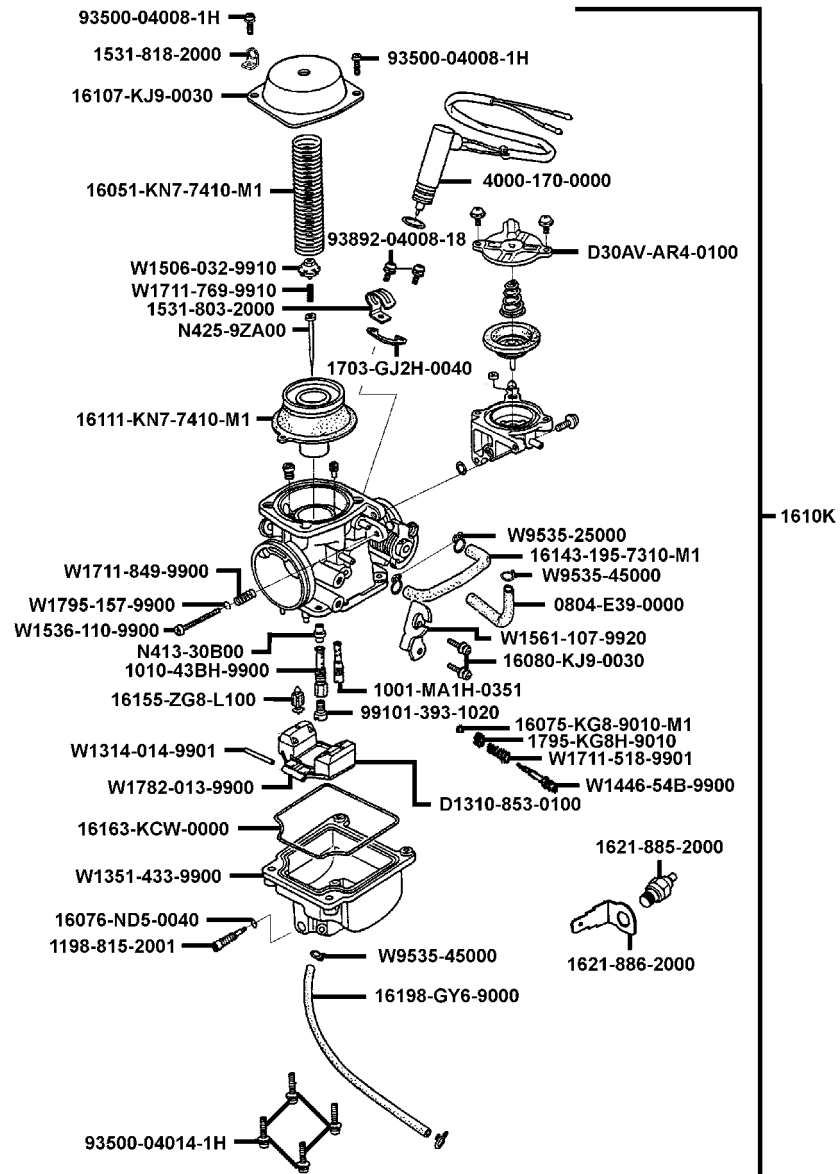

販賣記號 Sales mark	項目 Ref no	零件號碼 Part no	版數 Ver	英文名稱 Description	中文名稱 Chinese	需要用量 Regd no	參考價 Ref Price
		0804-E39-0000	0	TUBE	通氣管	1	
		1001-MA1H-0351	0	SLOW JET	慢速噴油嘴	1	
		1010-43BH-9900	0	NEEDLE JET	小噴油嘴	1	
		1198-815-2001	0	DRAIN SCREW	溢流孔螺絲	1	
		1531-803-2000	0	BINDER	線夾	1	
		1531-818-2000	0	BINDER	線夾	1	
		16051-KN7-7410-M1	0	SPG COMPR	彈簧	1	
		16075-KG8-9010-M1	0	O RING	O環	1	
		16076-ND5-0040	0	O RING	O環	1	
		16080-KJ9-0030	0	SCREW PAN	螺絲	2	
		16107-KJ9-0030	0	TOP SET	真空活塞閥蓋	1	
		1610K-KKC1-EZ0	0	CARBURETOR ASSY	化油器	1	
		16111-KN7-7410-M1	0	VACUUM PISTON COMP	真空活塞閥	1	
		16143-195-7310-M1	0	TUBE	通氣管	1	
		16155-ZG8-L100	0	FLOAT VALVE COMP	浮筒閥	1	
		16163-KCW-0000	0	FLOAT CHAMPER GASKET	浮筒室墊圈	1	
		16198-GY6-9000	0	TUBE	溢流管	1	
		1621-885-2000	0	HEATER	加熱器	1	
		1621-886-2000	0	TERMINAL	接地板	1	
		1703-GJ2H-0040	0	SET PLATE	固定板	1	

E 9 Carburetor

化油器

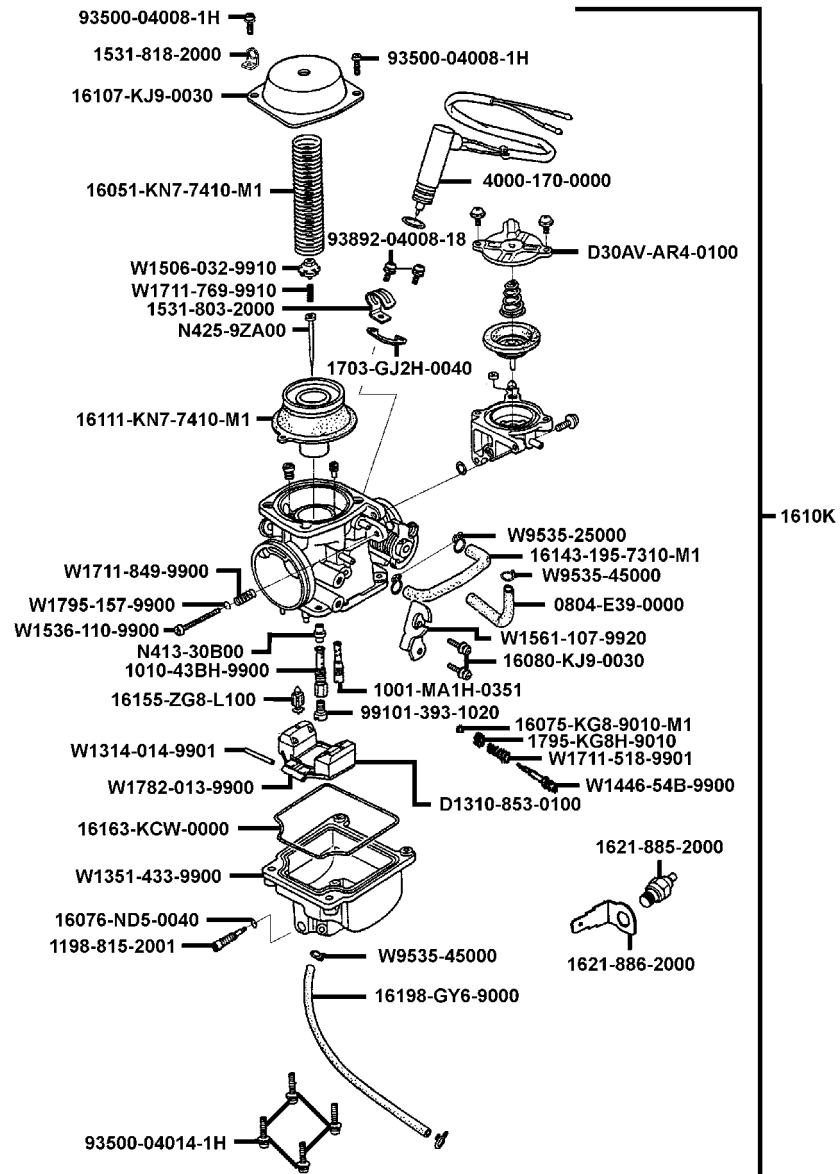

販賣記號 Sales mark	項目 Ref no	零件號碼 Part no	版數 Ver	英文名稱 Description	中文名稱 Chinese	需要用量 Regd no	參考價 Ref Price
		1795-KG8H-9010	0	WASHER PLAIN	平華司	1	
		4000-170-0000	0	AUTO BYSTARTER SET	自動旁通器	1	
		93500-04008-1H	0	SCREW PAN	螺絲	2	
		93500-04014-1H	0	SCREW PAN	螺絲	4	
		93892-04008-18	0	SCREW WASHER	螺絲	2	
		99101-393-1020	0	MAIN JET	主噴油嘴	1	
		D1310-853-0100	0	FLOAT COMP	浮筒組	1	
		D30AV-AR4-0100	0	A.C.V. ASSY	阻風閥組	1	
		N413-30B00	0	NEEDLE JET HOLDER	油針支座	1	
		N425-9ZA00	0	JET NEEDLE COMP	油針	1	
		W1314-014-9901	0	ARM PIN	浮筒閥臂銷	1	
		W1351-433-9900	0	FLOAT CHAMOPER BODY	浮筒室本體	1	
		W1446-54B-9900	0	SCREW ADJUST	調整螺絲	1	
		W1506-032-9910	0	VALVE PLATE	阻板	1	
		W1536-110-9900	0	STOP SCREW	調整螺絲	1	
		W1561-107-9920	0	STAY WIRE	起動閥配線支架	1	
		W1711-518-9901	0	SPG COMPR	彈簧	1	
		W1711-769-9910	0	SPG COMPR	彈簧	1	
		W1711-849-9900	0	SPG COMPR	彈簧	1	
		W1782-013-9900	0	SPECIAL CLIP[特殊管夾	1	

E 9 Carburetor

化油器

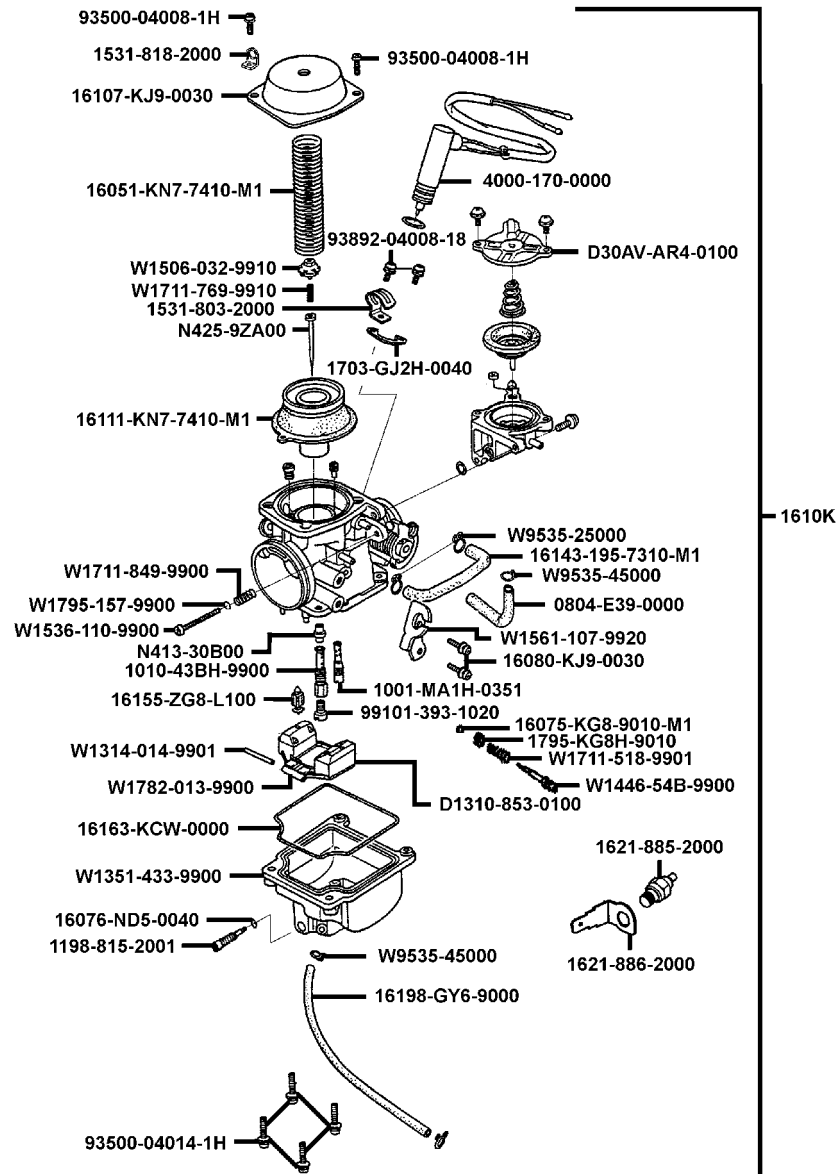

E 9

販賣記號 Sales mark	項目 Ref no	零件號碼 Part no	版數 Ver	英文名稱 Description	中文名稱 Chinese	需要用量 Regd no	參考價 Ref Price
		W1795-157-9900	0	PLAIN WASHER	平華司	1	
		W9535-25000	0	TUBE CLIP	管夾	2	
		W9535-45000	0	TUBE CLIP	管夾	2	

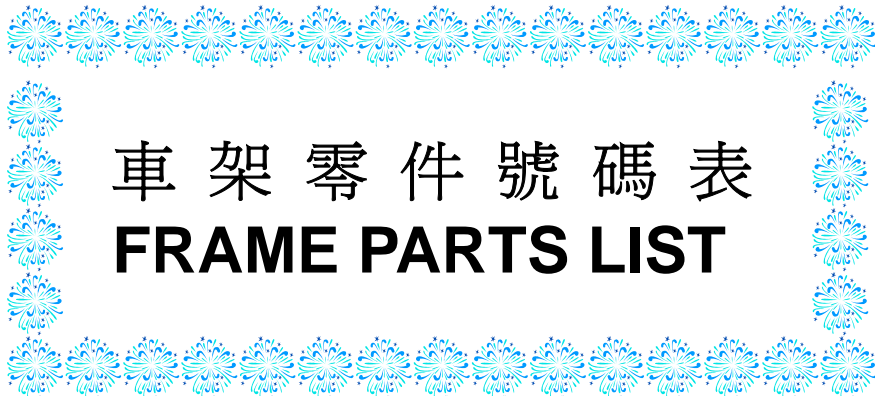

車架零件號碼表
FRAME PARTS LIST

F 1 Head Light

前
燈

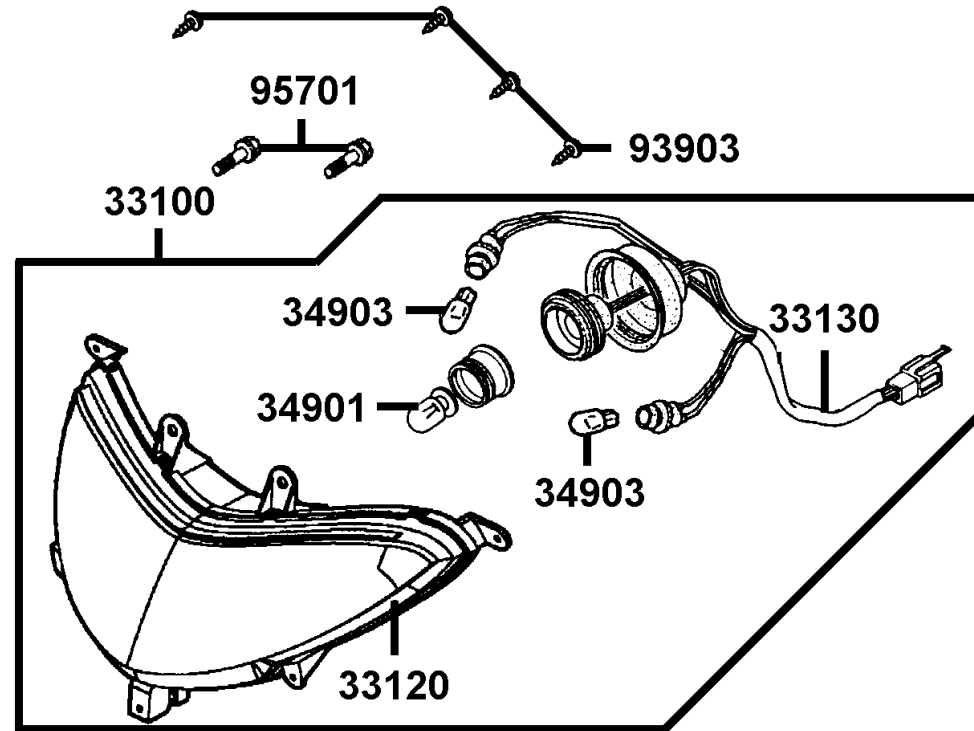

販賣記號 Sales mark	項目 Ref no	零件號碼 Part no	版數 Ver	英文名稱 Description	中文名稱 Chinese	需要用量 Regd no	參考價 Ref Price
		33100-KKC4-E000	3	LIGHT ASSY HEAD	前燈總成	1	
		33120-KKC4-E000	1	UNIT HEAD LIGHT	前燈殼	1	
		33130-KKC4-E000	0	SOCKET COMP HEAD	前燈配線	1	
		34901-KED9-900	0	BULB HEAD LIGHT	前燈泡	1	
		34903-KCP-9000	0	BULB POSITION LIGHT	燈泡	2	
		93903-35380	0	SCREW TAPPING 5*16	螺釘 5*16	4	
		95701-06012-08	0	BOLT FLANGE 6*12	螺絲 6*12	2	

F 1

F 2 Speedometer

儀
錶

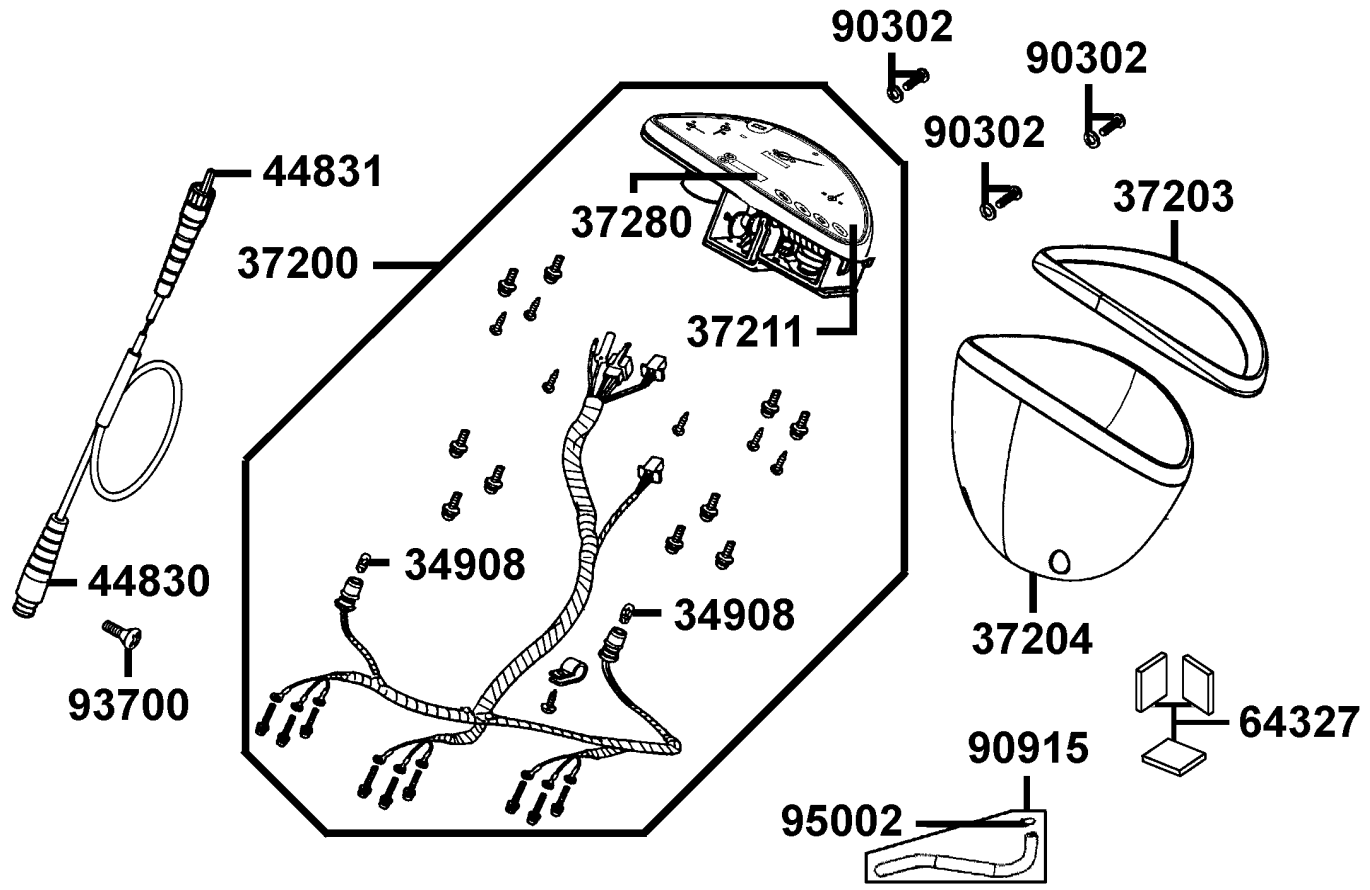

販賣記號 Sales mark	項目 Ref no	零件號碼 Part no	版數 Ver	英文名稱 Description	中文名稱 Chinese	需要用量 Regd no	參考價 Ref Price
		34908-MB9-8710-M1	0	BULB WEDGE BASE	儀錶內指示燈泡	2	
		37200-KKC1-E00	5	METER ASSY SPEED	儀錶	1	
**		37203-KKC3-900	0	METER COVER FR	儀錶上蓋	1	
**		37204-KKC3-900	0	METER COVER RR	儀錶下蓋	1	
		37211-KKC3-9000	0	LENS ASSY	儀錶蓋	1	
		37280-KKC3-9000	0	LCD ASSY (CLOCK)	電子時鐘	1	
		44830-KKC4-9000	2	CABLE COMP SPDMT	速度錶導線	1	
		44831-KKC4-9000	0	CABLE INNER	速度錶內導線	1	
		64327-KKC4-900	0	SPONGE TAPE METER COVER	儀錶蓋海綿膠帶	3	
		90302-GY6-9400	0	BOLT WASF 5*16	螺絲5X16	3	
		90915-KKC4-9000	0	TUBE DRAIN	洩流管	1	
		93700-05018-0H	0	SCREW OVAL 5*18	螺絲 5X18	1	
		95002-50000	0	CLIP C9 TUBE	管夾	1	

F 2

F 3 Handle Steering ● Handle Cover

轉
向
手
柄
●
手
柄
蓋

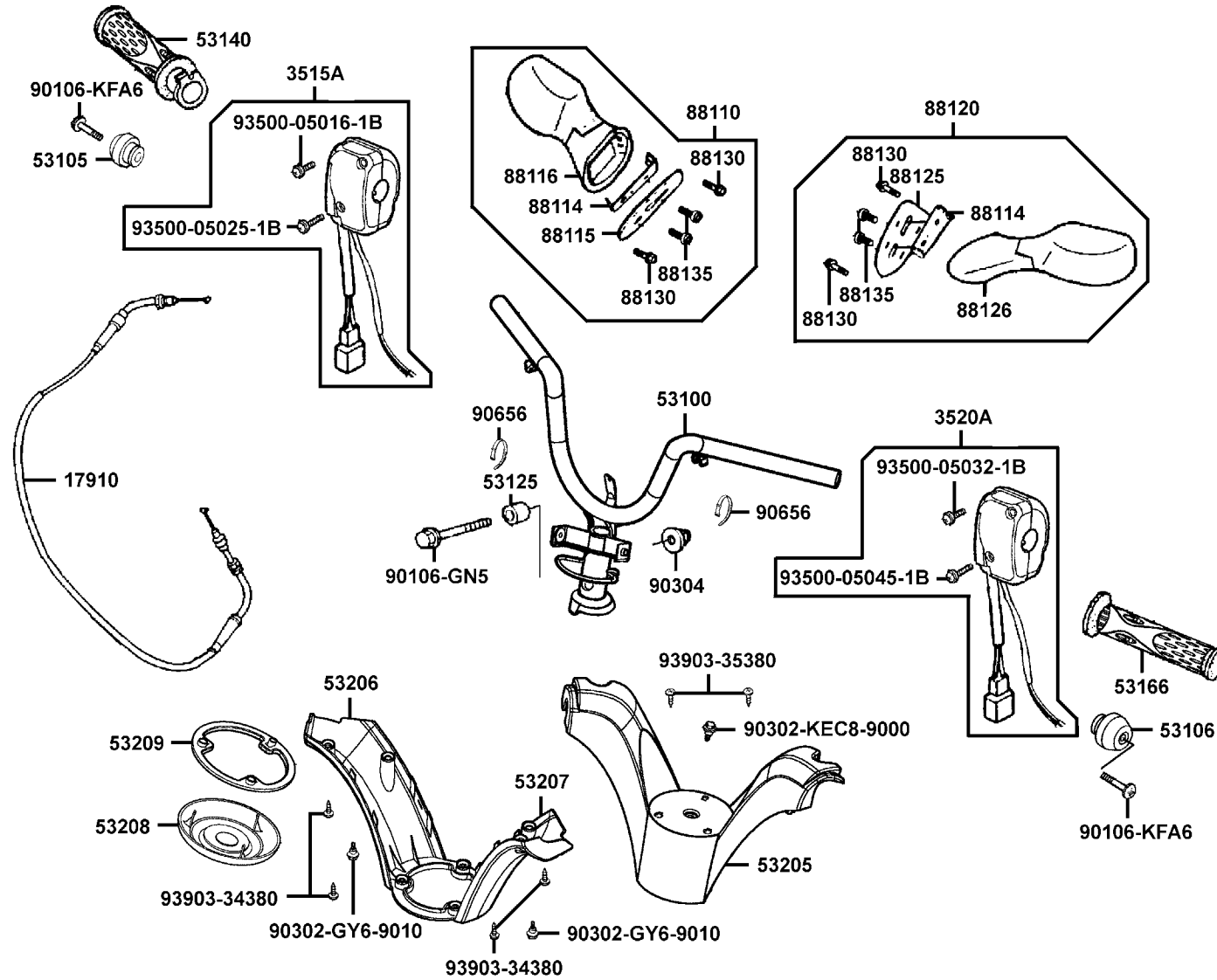

販賣記號 Sales mark	項目 Ref no	零件號碼 Part no	版數 Ver	英文名稱 Description	中文名稱 Chinese	需要用量 Regd no	參考價 Ref Price
		17910-KKC3-9000	1	CABLE COMP THROT	節流導線	1	
		3515A-KKC2-E000	0	SW ASSY RH HNDL COMP	右邊開關組	1	
		3520A-KBE-9000	2	SW ASSY L HNDL COMP	左邊開關組	1	
		53100-KKC4-9000	0	HANDLE COMP STRG	轉向手柄	1	
		53105-KKC4-900	0	END R STRG HANDLE	手柄右平衡端子	1	
		53106-KKC4-900	0	END L STRG HANDLE	手柄左平衡端子	1	
		53125-GN5-9010	0	COLLAR HANDLE SET	套筒	1	
**		53140-KKC3-900	0	GRIP COMP THROT	節流管套組	1	
**		53166-KGB5-900	0	GRIP L HANDLE	手柄左橡皮套	1	
**		53205-KKC4-900	0	COVER HNDL UP	手柄上蓋	1	
**		53206-KKC4-900	0	COVER R HANDLE LOW	手柄下蓋右側蓋	1	
**		53207-KKC4-900	0	COVER L HANDLE LOW	手柄下蓋左側蓋	1	
**		53208-KKC4-900	0	GRILL HANDLE UP	手柄底蓋	1	
		53209-KKC4-9000	0	PACKING HANDLE UP	手柄底蓋襯墊	1	
**		88110-KKC3-900	4	MIRROR ASSY R BACK	右後視鏡	1	
		88114-KKC4-9000	3	STAY MIRROR	後視鏡鐵座	2	
		88115-KKC4-9000	0	PAD R MIRROR	右後視鏡襯墊	1	
		88116-KKC4-9000	3	BASE R MIRROR	右後視鏡底座	1	
**		88120-KKC3-900	4	MIRROR ASSY L BACK	左後視鏡	1	
		88125-KKC4-9000	0	PAD L MIRROR	左後視鏡襯墊	1	

F 3 Handle Steering ● Handle Cover

轉向手柄 ● 手柄蓋

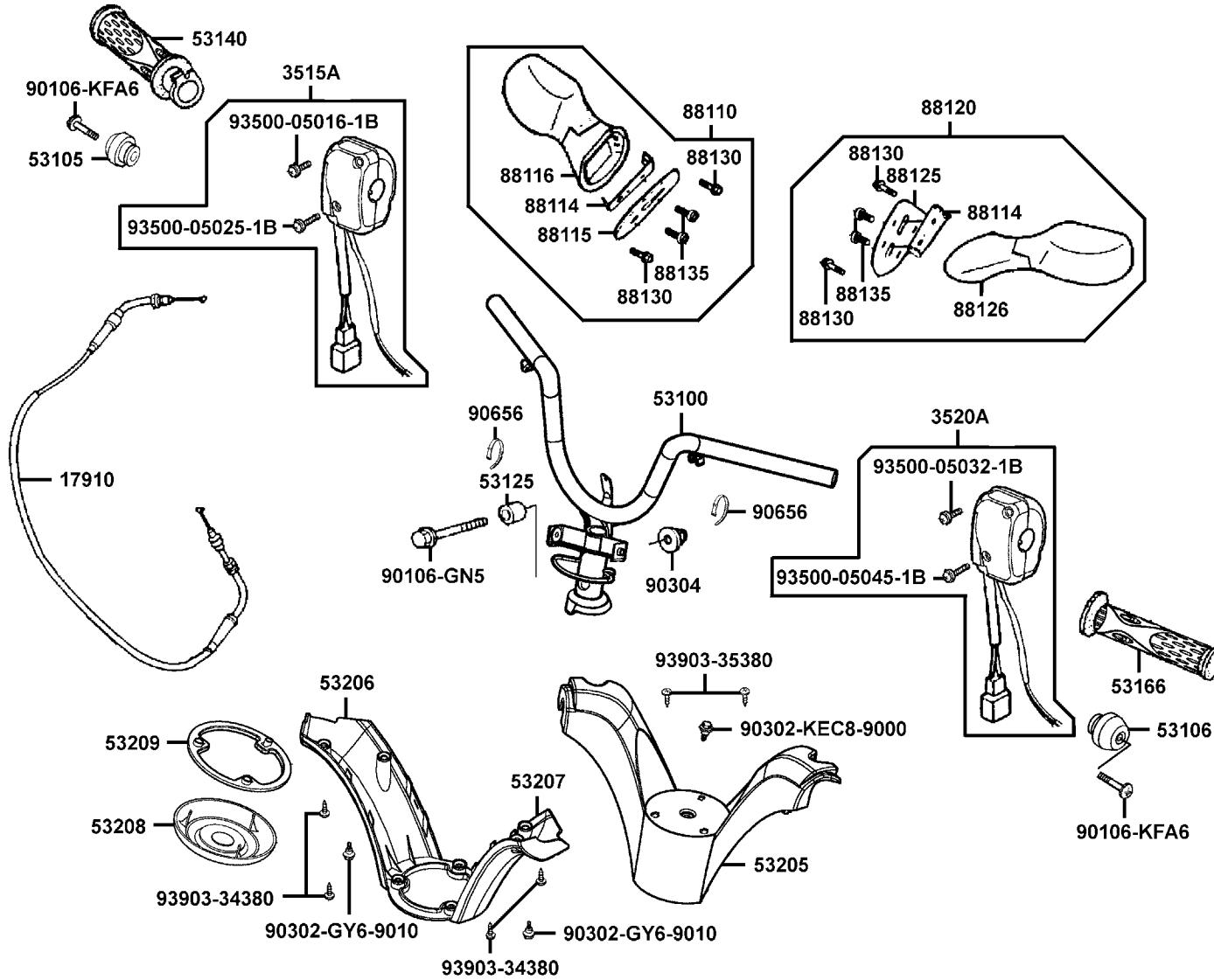

販賣記號 Sales mark	項目 Ref no	零件號碼 Part no	版數 Ver	英文名稱 Description	中文名稱 Chinese	需要用量 Regd no	參考價 Ref Price
		88126-KKC4-9000	3	BASE L MIRROR	左後視鏡底座	1	
		88130-KKC4-9000	0	BOLT SPECIAL	特殊螺絲	4	
		88135-KKC4-9000	1	SCREW PAN 5*20	螺絲 5*20	4	
		90106-GN5-9010	0	BOLT FLANGE 10*50	特殊螺絲 10X50	1	
		90106-KFA6-9000	0	BOLT WASH 8*75	螺絲 8*75	2	
		90302-GY6-9010	0	BOLT WASH 5*12	螺絲 5X12	2	
		90302-KEC8-9000	0	BOLT PAN 5*9	螺釘 5*9	1	
		90304-GE8-0040	1	NUT U 10MM	螺帽 10MM	1	
		90656-GY6-9110	0	BAND OIL HOSE	油管束帶	2	
		93500-05016-1B	0	SCREW PAN 5*16	螺絲 5X16	1	
		93500-05025-1B	0	SCREW PAN 5*25	螺絲 5X25	1	
		93500-05032-1B	0	SCREW PAN 5*32	螺絲 5X32	1	
		93500-05045-1B	0	SCREW PAN 5*45	螺絲 5X45	1	
		93903-34380	0	SCREW TAPPING 4*12	螺釘 4X12	4	
		93903-35380	0	SCREW TAPPING 5*16	螺釘 5*16	2	

F 3

F 4 Brake Master Cylinder

煞車主油缸

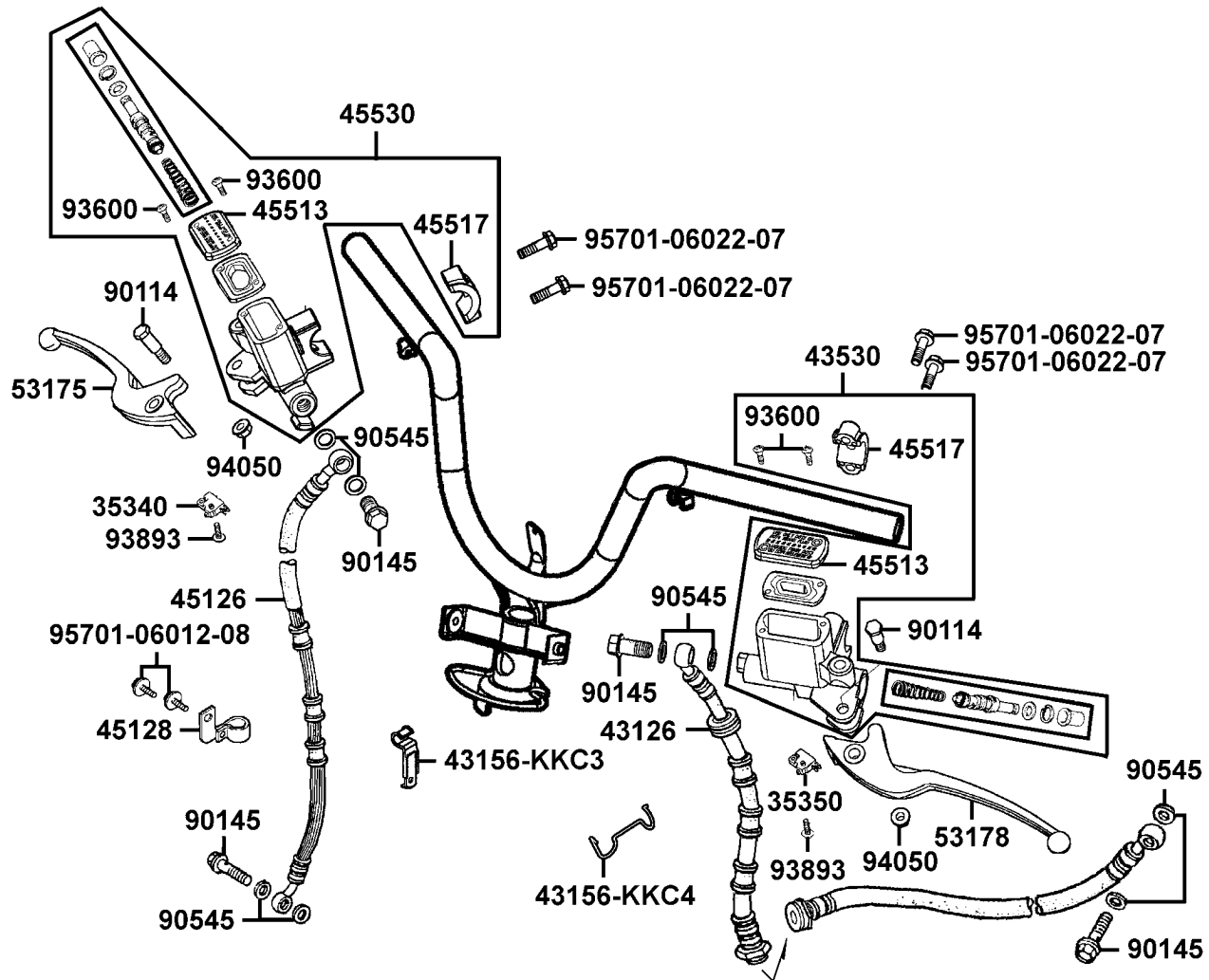

販賣記號 Sales mark	項目 Ref no	零件號碼 Part no	版數 Ver	英文名稱 Description	中文名稱 Chinese	需要用量 Regd no	參考價 Ref Price
		35340-KBN-9000	0	SW ASSY FR STOP	煞車燈前置開關	1	
		35350-KBN-9000	0	SW ASSY RR STOP	煞車燈後置開關	1	
		43126-KKC2-E000	1	HOSE ASSY RR BRAAKE	後煞車油管	1	
		43156-KKC3-9000	0	CLAMPER B HOSE RR	後煞車油管夾 B	1	
		43156-KKC4-9000	1	CLAMPER HOSE RR	後煞車管夾	1	
		43530-KFC8-3050	1	CYLN SET RR MASTER	後煞車主油缸	1	
		45126-KKC2-9000	1	HOSE ASSY FR BRK	前煞車油管	1	
		45128-KBE-9000	0	CLAMPER FR BRAKE HOSE	前煞車油管夾	1	
		45513-KCX-M000-US	1	CAP MASTER CYLINDER	煞車主油缸蓋	2	
		45517-KAF-9100	0	HOLDER M/C	主油缸固定座	2	
		45530-KFC8-E000-IT	2	CYLN SET FR MASTER	前煞車主油缸	1	
**		53175-KFA5-E10	0	LEVER R STRG HNDL	手柄右拉桿	1	
**		53178-KFC8-E10	0	LEVER L STRG HNDL	手柄左拉桿	1	
		90114-166-0070	1	BOLT HANDLE LEVER	右拉桿固定螺栓	2	
		90145-MS9-6120-M1	0	OIL BOLT 10*22	油管螺絲 10X22	4	
		90545-300-0010	2	WASHER OIL BOLT	華司	8	
		93600-04012-1G	0	SCREW FLAT 4*12	螺絲 4X12	4	
		93893-04012-18	0	SCREW WASHER 4*12	螺絲 4X12	2	
		94050-06080	0	BOLT FLANGE 6MM	螺帽 6MM	2	
		95701-06012-08	0	BOLT FLANGE 6*12	螺絲 6X12	2	

F 4

F 4 Brake Master Cylinder

煞車主油缸

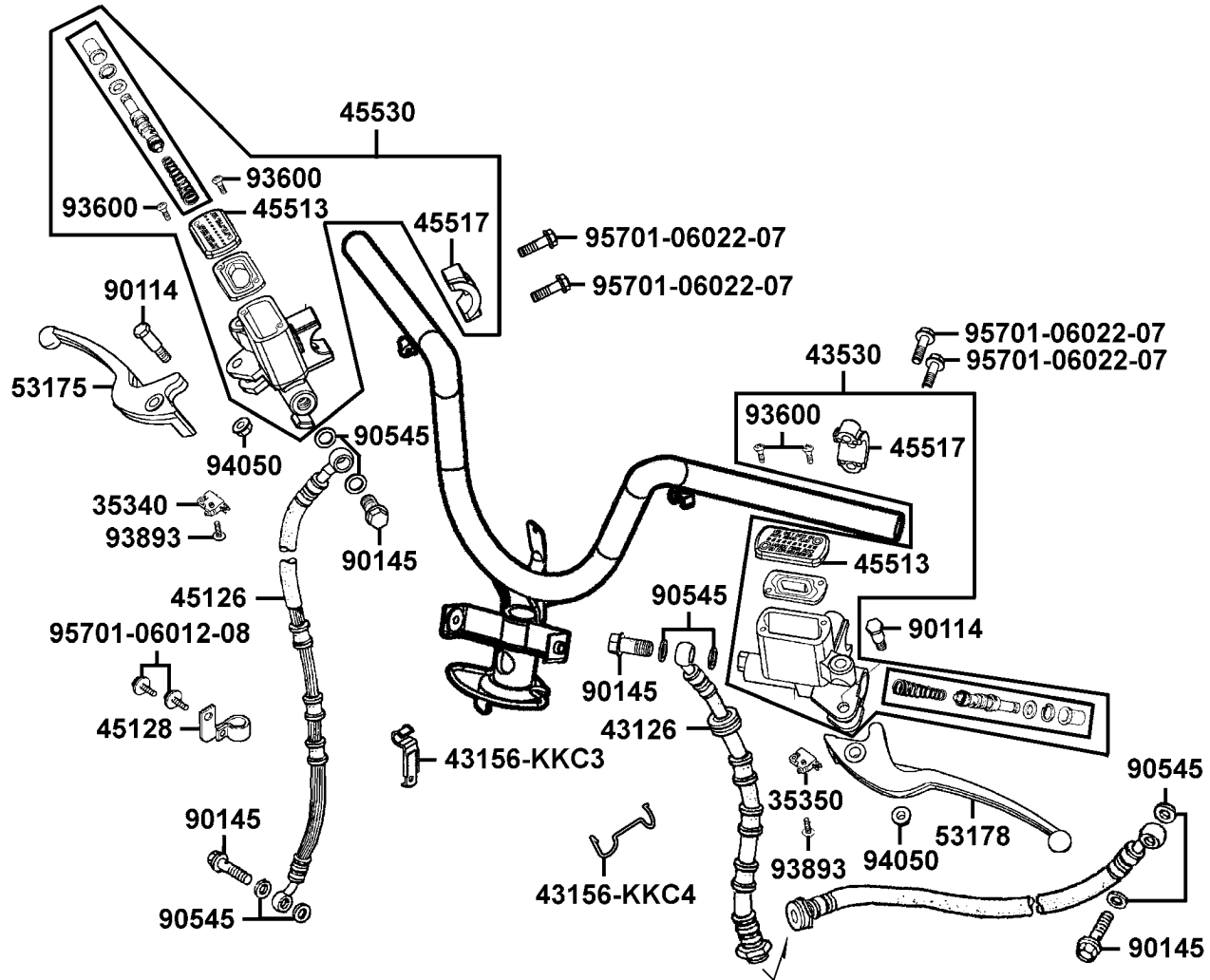

販賣記號 Sales mark	項目 Ref no	零件號碼 Part no	版數 Ver	英文名稱 Description	中文名稱 Chinese	需要用量 Regd no	參考價 Ref Price
--------------------	--------------	-----------------	-----------	---------------------	-----------------	-----------------	------------------

F 4

	95701-06022-07		0	BOLT FLANGE 6*22	螺絲 6X22	4	
--	----------------	--	---	------------------	---------	---	--

F 5 Front Cover ● Floor Panel

前護蓋 ● 腳踏板

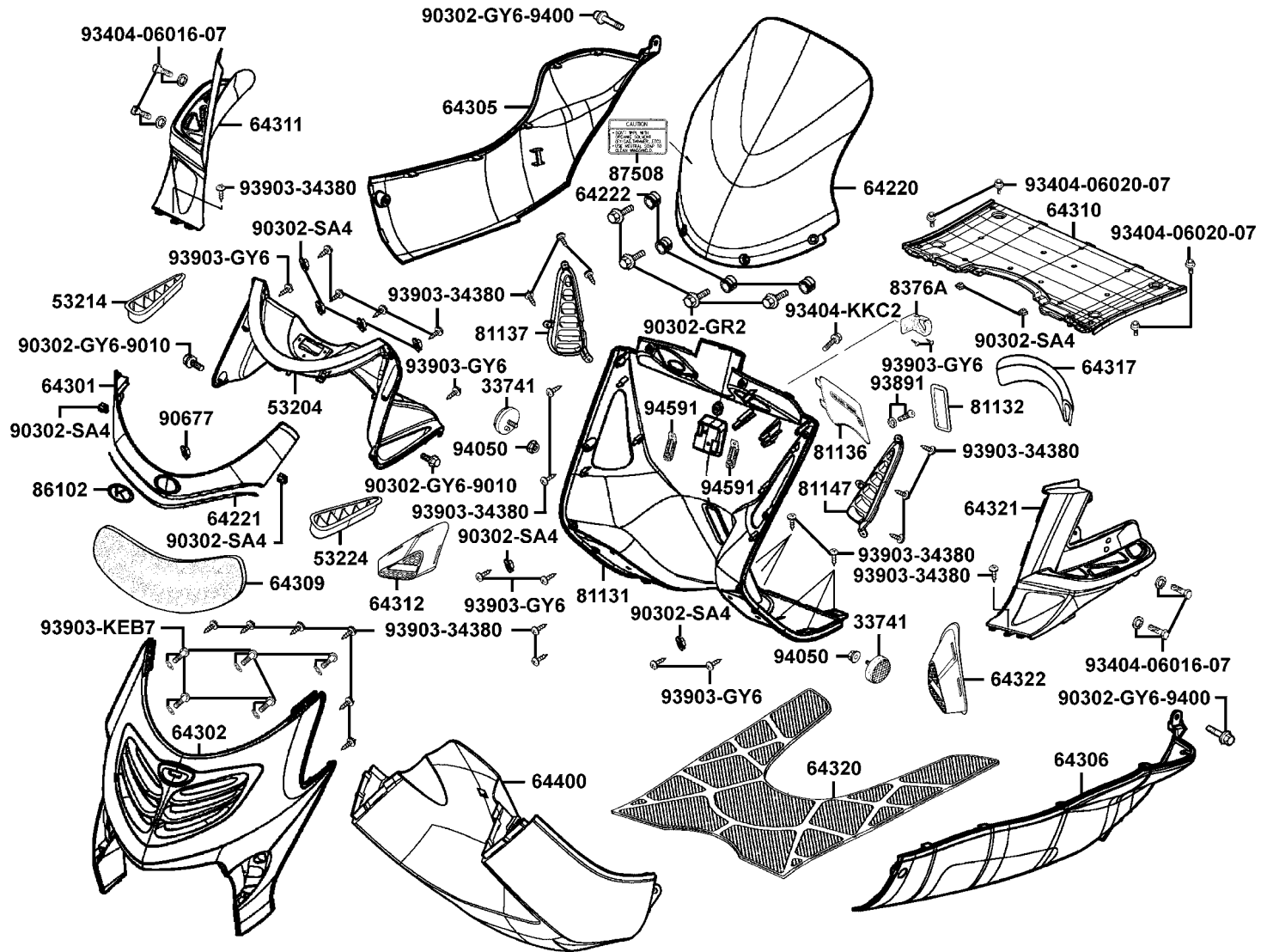

販賣記號 Sales mark	項目 Ref no	零件號碼 Part no	版數 Ver	英文名稱 Description	中文名稱 Chinese	需要用量 Regd no	參考價 Ref Price
		33741-GY6-C300	1	REFLEX REFLECTOR	反光鏡片	2	
**		53204-KKC4-900	2	COVER METER	儀錶外蓋	1	
**		53214-KKC4-900	0	GRID R METER COVER	儀表外蓋右格板	1	
**		53224-KKC4-900	0	GRID L METER COVER	儀表外蓋左格板	1	
		64220-KKC4-9000	0	WIND SCREEN	遮陽板	1	
		64221-KKC4-9000	0	SEAL WIND SCREEN	橡皮	1	
		64222-KKC4-9000	3	RUBBER WIND SCREEN	遮陽板橡皮	4	
**		64301-KKC4-900	0	COVER SCREEN	前燈上蓋	1	
**		64302-KKC4-900	0	MOLDING FR	前護板	1	
**		64305-KKC4-900	1	SKIRT R SIDE	右邊軌	1	
**		64306-KKC4-900	2	SKIRT L SIDE	左邊軌	1	
		64309-KKC4-9000	0	GRILL FR COVER	前蓋格板	1	
**		64310-KKC4-900	0	FLOOR PANEL	腳踏板	1	
**		64311-KKC4-900	3	COVER R PILLION STEP	後座右踏板蓋	1	
**		64312-KKC4-900	3	GRID R PILLION STEP	後座右踏板蓋格板	1	
		64317-KKC4-9000	0	SEAL METER COVER FR	碼表蓋防水封	1	
**		64320-KKC4-900	0	MAT FLOOR	腳踏板橡皮墊	1	
**		64321-KKC4-900	2	COVER L PILLION STEP	後座左踏板蓋	1	
**		64322-KKC4-900	1	GRID L PILLION STEP	後座左踏板蓋格板	1	
**		64400-KKC4-900	0	COWL UNDER	下罩	1	

F 5 Front Cover●Floor Panel

前護蓋●腳踏板

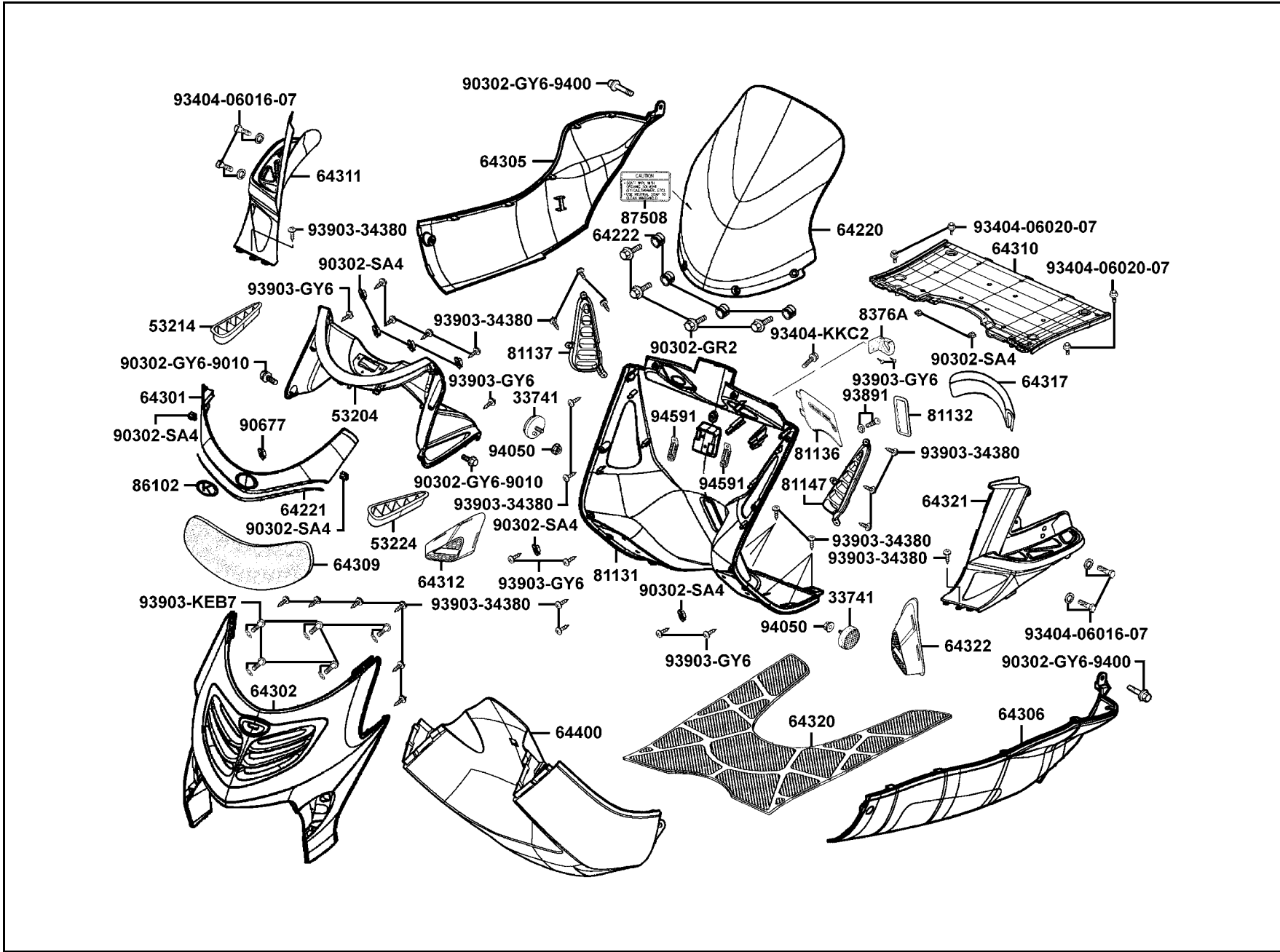

販賣記號 Sales mark	項目 Ref no	零件號碼 Part no	版數 Ver	英文名稱 Description	中文名稱 Chinese	需要用量 Regd no	參考價 Ref Price
**		81131-KKC4-900	0	LEG SHIELD	行旅內箱	1	
**		81132-KEB7-900	0	LID LEG SHIELD	內箱蓋	1	
**		81136-KKC4-900	0	LID RESERVE TANK	儲備油箱蓋	1	
**		81137-KKC4-900	0	GRID R LEG SHIELD	內箱右通風格板	1	
**		81147-KKC4-900	0	GRID L LEG SHIELD	內箱左通風格板	1	
		8376A-KBE-900	3	CLIP ASSY CENTER	中心掛鉤	1	
		86102-KFA6-E00	0	EMB K-LOGO 30MM	標誌	1	
		87508-KKC4-E00	0	LABEL CLEANNESS CAUYION	貼紙	1	
		90302-GR2-0000	1	BOLT WASH 5*16	螺絲 5*16	4	
		90302-GY6-9010	0	BOLT WASHER 5*12	螺絲 5X12	2	
		90302-GY6-9400	0	BOLT WASH 5*16	螺絲 5*16	2	
		90302-SA4-0040	1	NUT SPRING 4MM	螺帽 4MM	10	
		90677-GR1-0030	1	NUT CLIP 5MM	彈簧螺帽 5MM	1	
		93404-06016-07	0	BOLT WASHER 6*16	螺絲 6*16	4	
		93404-06020-07	0	BOLT WASH 6*20	螺絲 6*20	4	
		93404-KKC2-900	0	BOLT WASH 6*16	螺絲6*16	1	
		93891-05012-07	0	SCREW WASHER 5*12	螺絲 5*12	1	
		93903-34380	0	SCREW TAPPING 4*12	螺釘 4X12	28	
		93903-GY6-9000	0	SCREW TAPPING 4*14	螺釘 4X14	8	
		93903-KEB7-9000	0	SCREW WASH 4MM	螺絲華司 4MM	5	

F 5

F 5 Front Cover●Floor Panel

前護蓋●腳踏板

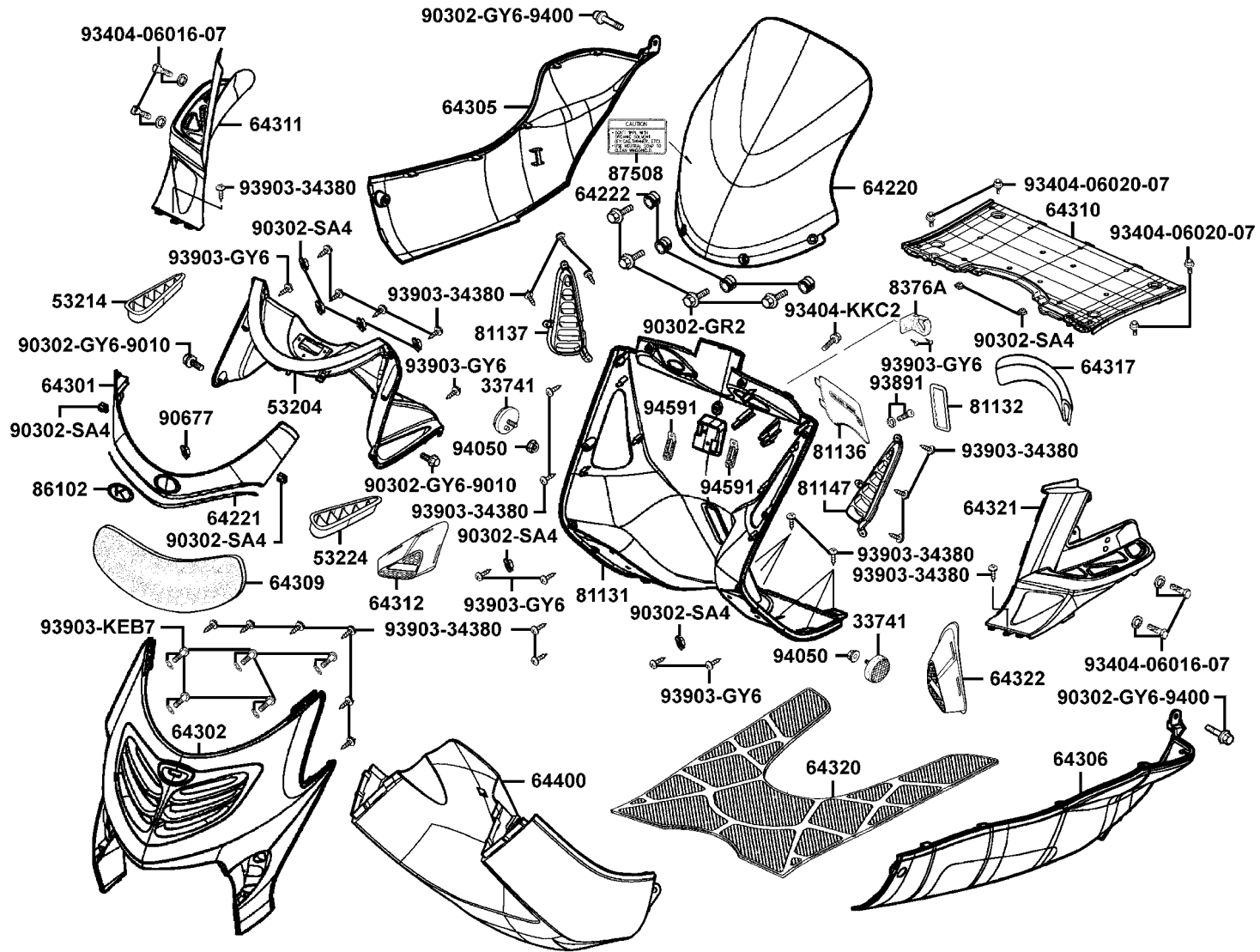

販賣記號 Sales mark	項目 Ref no	零件號碼 Part no	版數 Ver	英文名稱 Description	中文名稱 Chinese	需要用量 Regd no	參考價 Ref Price
		94050-06080	0	NUT FLANGE 6MM	螺帽 6MM	2	
		94591-27000	0	CLIP 2*70	邊蓋夾	2	

F 5

F 6 Front Cushion

前
避
震
器

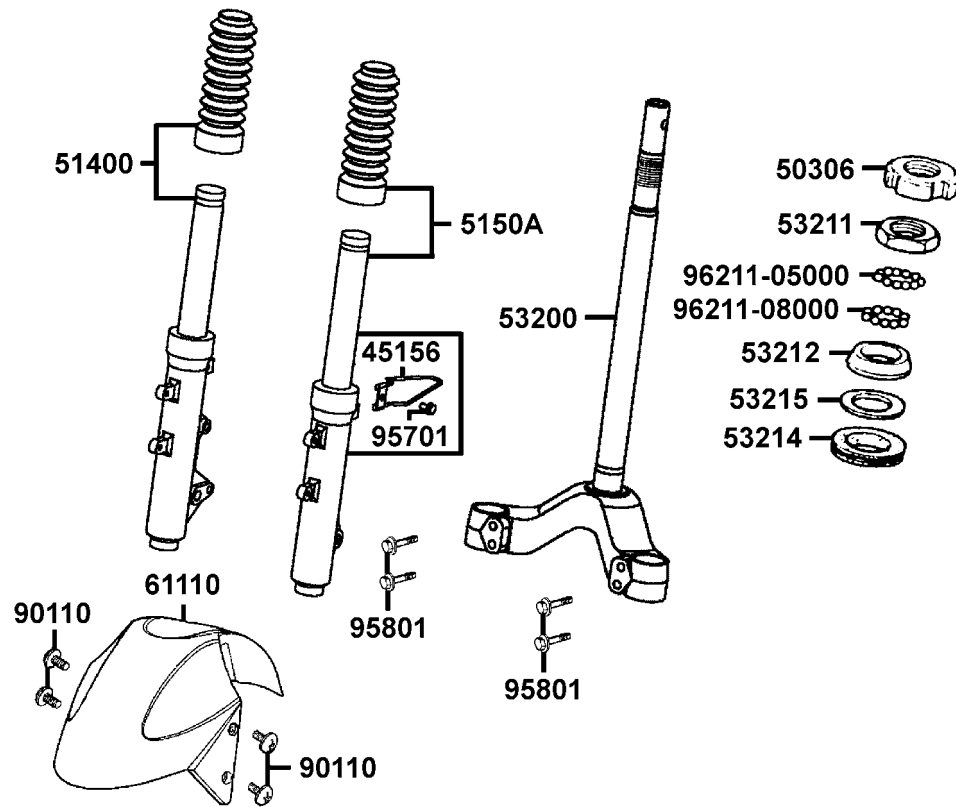

販賣記號 Sales mark	項目 Ref no	零件號碼 Part no	版數 Ver	英文名稱 Description	中文名稱 Chinese	需要用量 Regd no	參考價 Ref Price
		45156-KCE-9000	1	CLAMPER FR BRK CABLE	導線夾	1	
		50306-196-0010	0	NUT STRG STEM LOCK	主幹螺帽	1	
**		51400-KKC4-900	2	FORK ASSY R FR	右前避震器組	1	
**		5150A-KKC4-900	3	FORK SET L FR	左前避震器組	1	
		53200-KKC2-9000	1	STEM COMP STRG	轉向主桿	1	
		53211-GY6-9400	0	RACE STRG TOP CONE	上錐體座圈	1	
		53212-250-0110	0	RACE (STRG BOTTOM) CONE	下錐體座圈	1	
		53214-250-0010	0	DUST SEAL STRG (HEAD)	防塵油封	1	
		53215-250-0010	0	WASHER STRG HDL DUST-SEAL	華司	1	
**		61110-KHD8-900	2	FENDER FR	前土除	1	
		90110-KEB7-9000	0	SCREW SPECIAL 6*14	螺絲 6*14	4	
		95701-06012-08	0	BOLT FLANGE 6*12	螺絲 6*12	1	
		95801-08040-08	0	BOLT FLANGE 8*40	螺絲 8X40	4	
		96211-05000	0	BALL STEEL #5	鋼珠 #5	26	
		96211-08000	0	BALL STEEL #8	鋼珠 #8	19	

F 6

F 7 Front Wheel

前輪

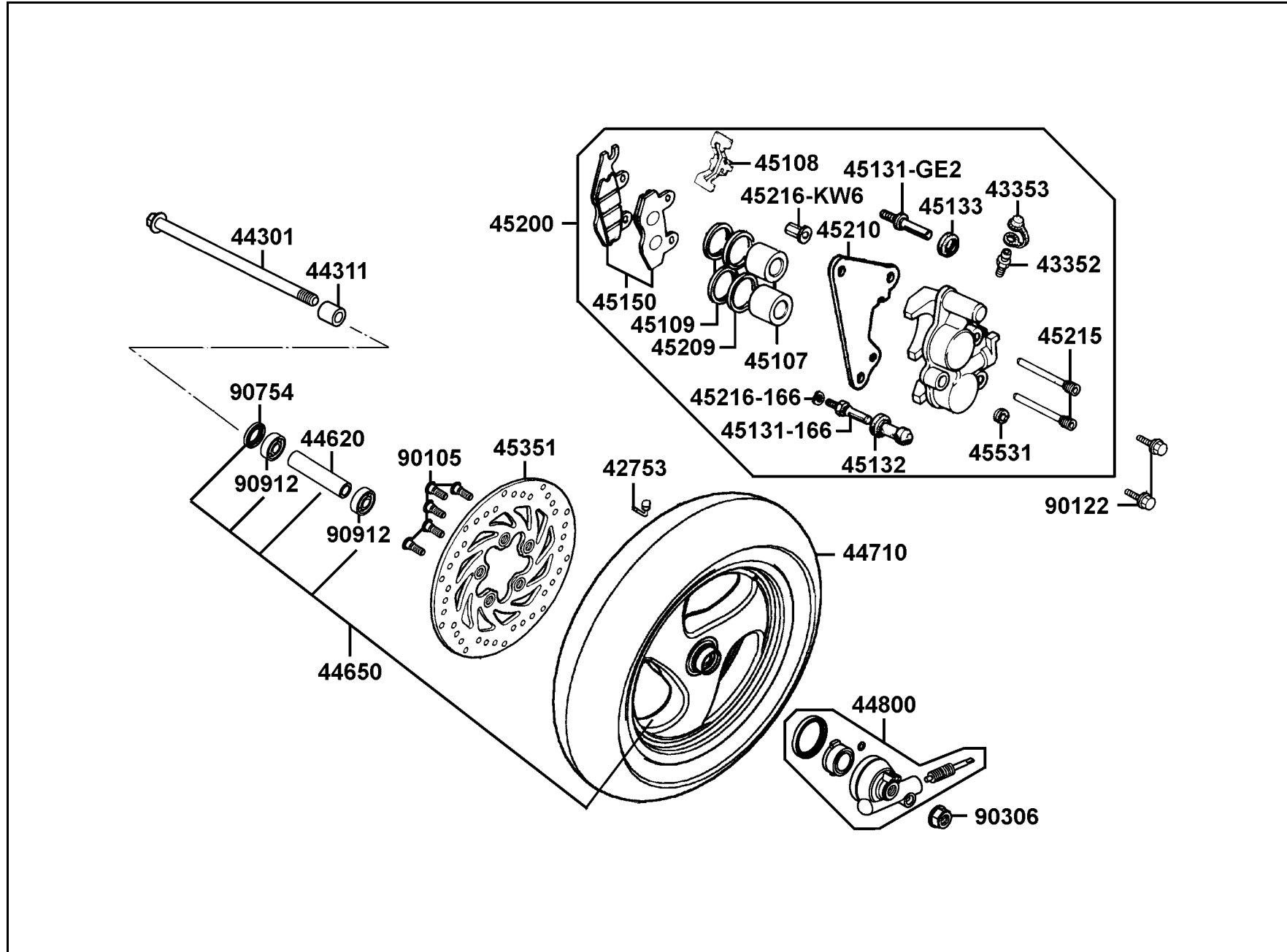

販賣記號 Sales mark	項目 Ref no	零件號碼 Part no	版數 Ver	英文名稱 Description	中文名稱 Chinese	需要用量 Regd no	參考價 Ref Price
		42753-KCX-9000	1	RIM VALVE (PVR-70B)	打氣嘴	1	
		43352-568-0030	3	SCREW BLEEDER	加油嘴	1	
		43353-461-7710-M1	0	CAP BLEEDER	加油嘴蓋	1	
		44301-KCX-900	1	AXLE FR WHEEL	前輪軸	1	
		44311-KBE-9000	0	COLLAR FR WHEEL SIDE	前輪邊套筒	1	
		44620-KHD8-9000	0	COLLAR FR AXLE DISTANCE	前輪軸距套筒	1	
**		44650-KHD8-30A	1	WHEEL SET FR	前輪圈組	1	
		44710-KKC4-900	2	TIRE ASSY FR	前輪胎	1	
		44800-KFA5-9000	1	GEAR BOX ASSY	速度齒輪箱組	1	
		45107-MN5-0070	0	PISTON	卡鉗活塞	2	
		45108-ML4-0060	2	PAD SPG	煞車摩擦片彈簧	1	
		45109-GE2-0060	0	DUST SEAL	防塵封	2	
		45131-166-0160	0	PIN BOLT	卡鉗螺絲銷	1	
		45131-GE2-0060	1	PIN BOLT A	卡鉗螺絲銷 A	1	
		45132-166-0160	0	BUSH BOOT PIN	卡鉗襯套	1	
		45133-MA3-0060	0	BOOT B	襯套	1	
		45150-LLB5-3050	0	PAD COMP	煞車摩擦板組	1	
**		45200-KKC2-E00	1	CALIPER ASSY FR	前煞車卡鉗	1	
		45209-GE2-0060	0	SEAL PISTON	油封	2	
		45210-KHD8-9000	0	BRACKET FR	前煞車卡鉗托架	1	

F 7 Front Wheel

前輪

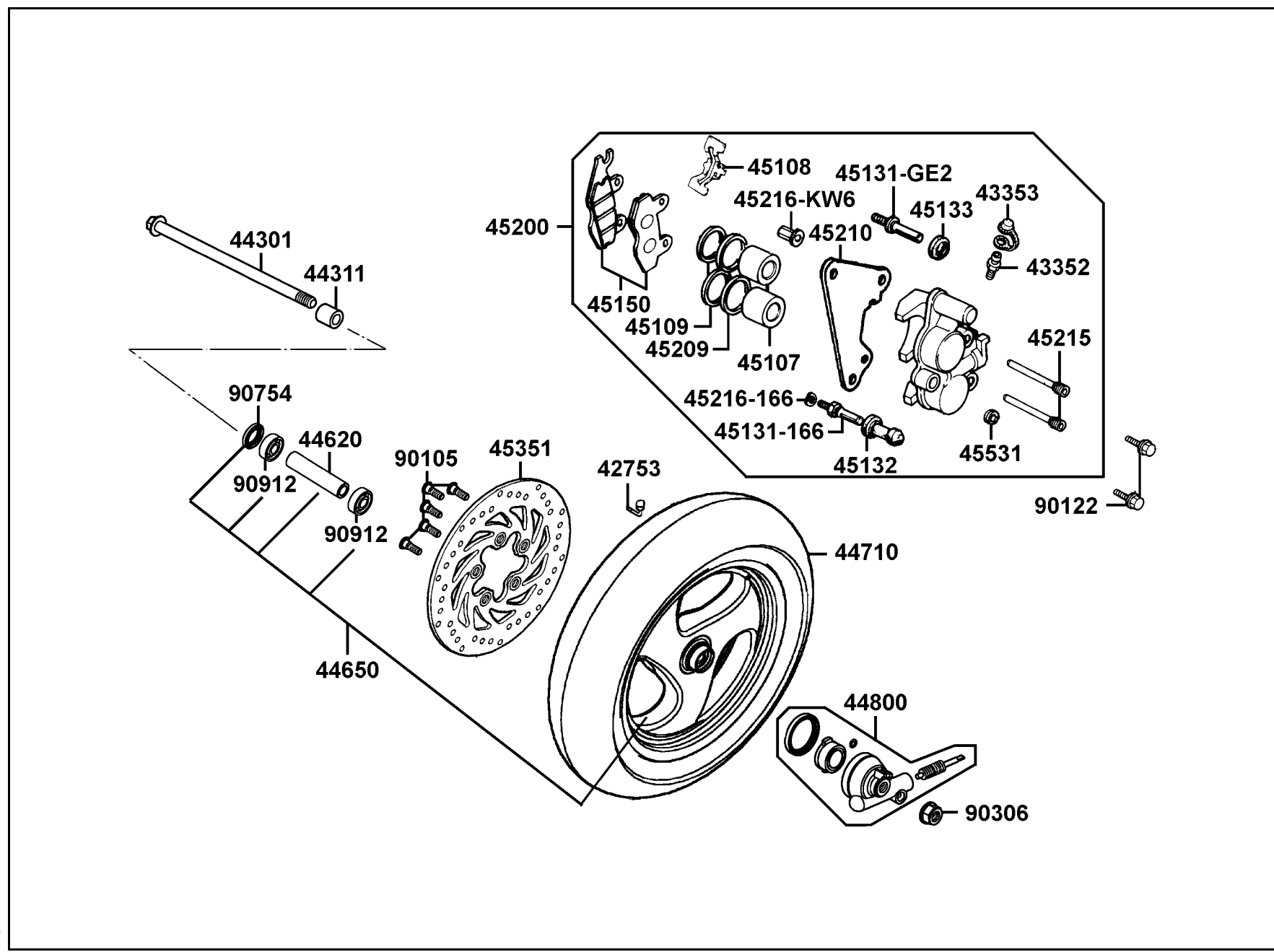

F7

販賣記號 Sales mark	項目 Ref no	零件號碼 Part no	版數 Ver	英文名稱 Description	中文名稱 Chinese	需要用量 Regd no	參考價 Ref Price
		45215-KCE-9000	0	PIN HANGER	卡鉗吊架銷	2	
		45216-166-0060	0	WASHER WAVE	華司	1	
		45216-KW6-9020-M1	0	TORQUE NUT	特殊螺帽	1	
		45351-KHE7-E000	0	DISK RR BRAKE	前煞車摩擦圓盤	1	
		45531-GR1-9510	0	PLUG	塞蓋	1	
		90105-KR3-0010	1	BOLT FR DISK 8*24	螺絲 8X24	5	
		90122-KBE-9000	0	BOLT FLANGE 8X32	螺絲 8X32	2	
		90306-GW0-9020-M1	0	NUT FLANGE 12MM	螺帽 12MM	1	
		90754-GC8-0000	0	DUST SEAL 20*32*5	油封 20X32X5	1	
		90912-KLF-00B	0	BEARING 6201 LLU	軸承 6201	2	

F 8 Rear Wheel

後輪

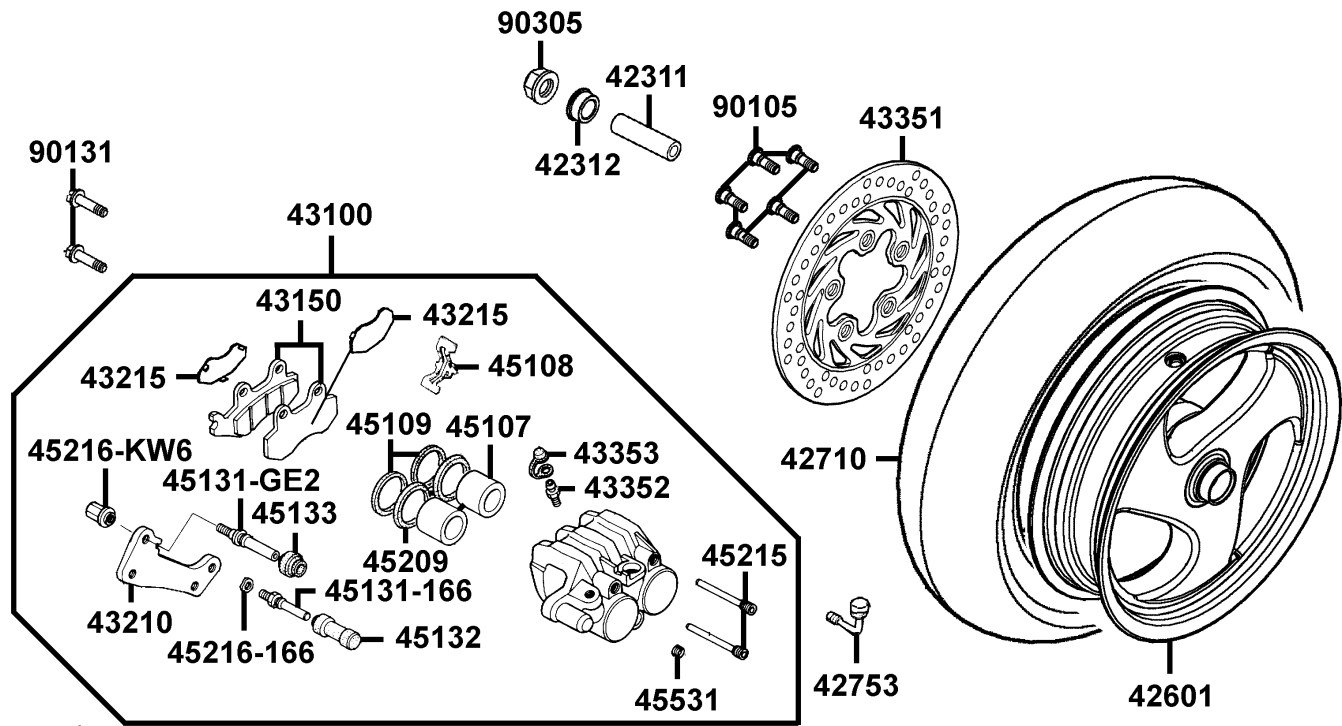

販賣記號 Sales mark	項目 Ref no	零件號碼 Part no	版數 Ver	英文名稱 Description	中文名稱 Chinese	需要用量 Regd no	參考價 Ref Price
		42311-KFC8-9000	2	COLLAR RR AXLE A	後輪軸套筒 A	1	
		42312-KBE-9000	0	COLLAR RR AXLE SIDE	後輪軸邊套筒	1	
**		42601-KHD8-90B	1	WHEEL RR CAST	後輪圈	1	
		42710-KKC3-900	0	TIRE ASSY RR	後輪胎	1	
		42753-004-9000	0	RIM VALVE (PVR 70)	打氣嘴	1	
**		43100-KBE-910	0	CALIPER ASSY RR	後煞車卡鉗組	1	
		43150-KBE-3060	0	PAD COMP	煞車摩擦板組	1	
**		43210-KBE-900	0	BRACKET RR	後煞車卡鉗托架	1	
		43215-KBE-9000	0	PAD HANGER	填隙片	2	
		43351-KHE7-E00	1	DISK RR BRAKE	後煞車摩擦圓盤	1	
		43352-568-0030	3	SCREW BLEEDER	加油嘴	1	
		43353-461-7710-M1	0	CAP BLEEDER	加油嘴蓋	1	
		45107-MN5-0070	0	PISTON	卡鉗活塞	2	
		45108-ML4-0060	2	PAD SPG	摩擦板彈簧	1	
		45109-GE2-0060	0	DUST SEAL	防塵封	2	
		45131-166-0160	0	PIN BOLT	卡鉗螺絲銷	1	
		45131-GE2-0060	1	PIN BOLT A	卡鉗螺絲銷 A	1	
		45132-166-0160	0	BUSH BOOT PIN	襯套	1	
		45133-MA3-0060	0	BOOT B	襯套 B	1	
		45209-GE2-0060	0	SEAL PISTON	油封	2	

F 8 Rear Wheel

後輪

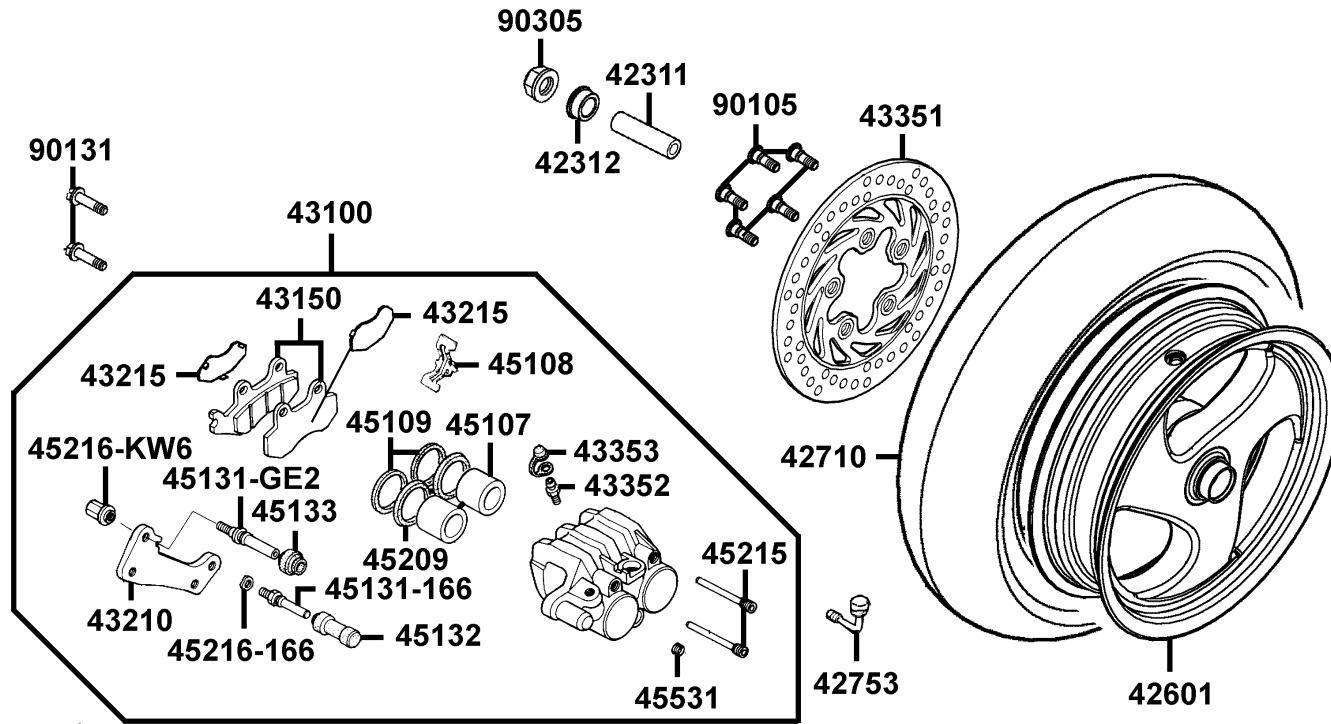

F 8

販賣記號 Sales mark	項目 Ref no	零件號碼 Part no	版數 Ver	英文名稱 Description	中文名稱 Chinese	需要用量 Regd no	參考價 Ref Price
		45215-KCE-9000	0	PIN HANGER	卡鉗吊架銷	2	
		45216-166-0060	0	WASHER WAVE	華司	1	
		45216-KW6-9020-M1	0	TORQUE NUT	螺帽	1	
		45531-GR1-9510	0	PLUG	塞蓋	1	
		90105-KR3-0010	1	BOLT FR DISK 8*24	螺絲 8X24	5	
		90131-GW0-9110	0	BOLT FLANGE 8*35	螺絲 8X35	2	
		90305-KW6-9120-M2	0	NUT U FLANGE 16MM	螺帽 16MM	1	

F 9 Seat

座墊

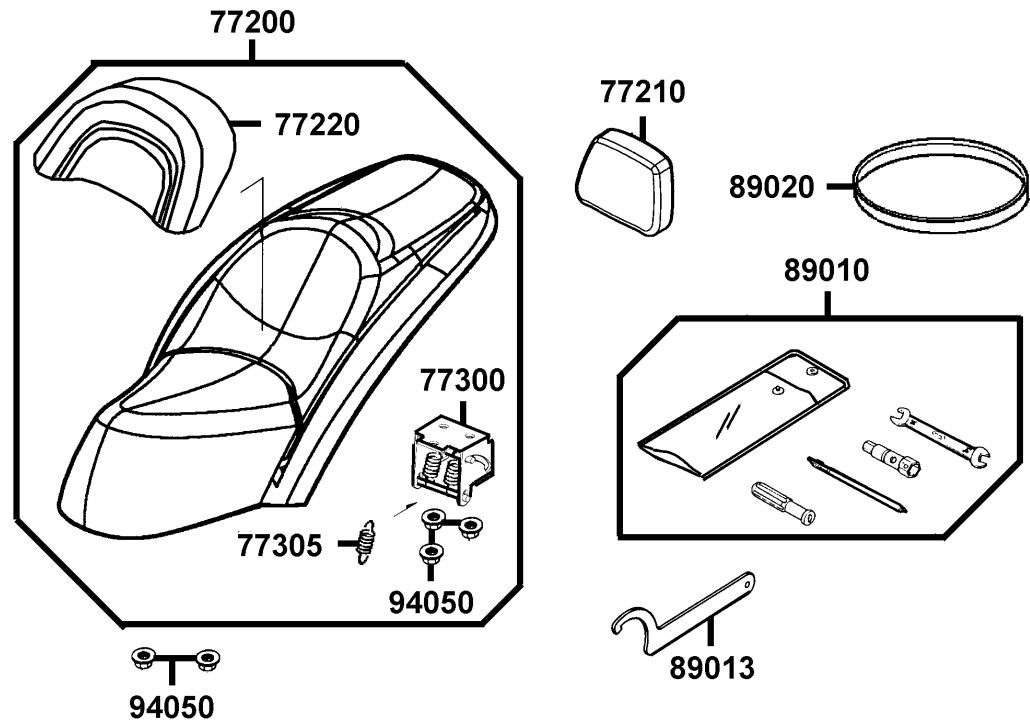

販賣記號 Sales mark	項目 Ref no	零件號碼 Part no	版數 Ver	英文名稱 Description	中文名稱 Chinese	需要用量 Regd no	參考價 Ref Price
**		77200-KKC4-E10	0	SEAT ASSY	座墊	1	
**		77210-KKC4-900	0	SEAT ASSY BACK	後座墊靠	1	
**		77220-KKC4-910	0	SEAT ASSY PAD	前座墊靠	1	
		77300-KKC4-900	3	HINGE ASSY SEAT	座墊鉸鏈	1	
		77305-KKC4-9000	1	SPRING HINGE	座墊鉸鏈彈簧	2	
		89010-KKC4-900	0	TOOL SET	工具包組	1	
		89013-KFC8-E000	1	ADJUSTER REAR CUSHION	後避震器調整工具	1	
		89020-KKC4-900	0	BAND TOOL SET	束帶	1	
		94050-06080	0	NUT FLANGE 6MM	螺帽 6MM	5	

F 10 Fuel Tank

油箱

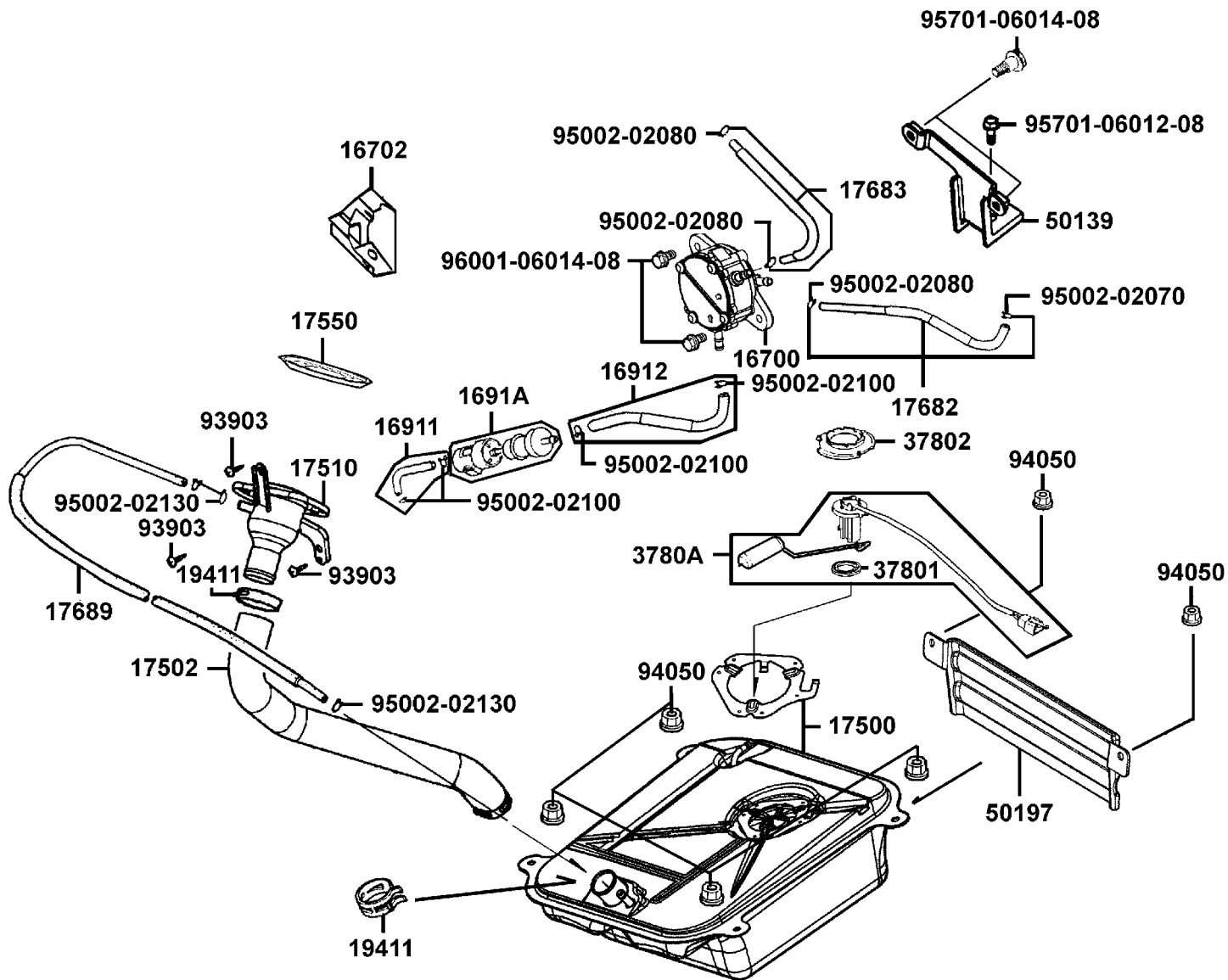

販賣記號 Sales mark	項目 Ref no	零件號碼 Part no	版數 Ver	英文名稱 Description	中文名稱 Chinese	需要用量 Regd no	參考價 Ref Price
		16700-KHE7-900	5	FUEL PUMP ASSY	汽油泵浦	1	
		16702-KBN-9010	1	COVER FUEL PUMP	汽油泵蓋	1	
		16911-KKC4-9000	0	TUBE ASSY TANK TO STRAINER	油管組	1	
		16912-KKC4-9000	0	TUBE ASSY STRAINER TO FUEL PUMP	油管組	1	
		1691A-KEC2-E000	0	STRAINER ASSY FUEL	汽油濾清器	1	
		17500-KKC4-9000	1	TANK COMP FUEL	油箱	1	
		17502-KKC4-9000	0	TUBE FUEL	油管	1	
		17510-KKC4-E000	0	PIPE ASSY FUEL FILLER	加油漏斗	1	
		17550-KHC4-9000	0	TRAY FUEL CAP	油箱護蓋	1	
		17682-KKC4-9000	0	TUBE ASSY FUEL VACUUM	真空管組	1	
		17683-KKC4-9000	0	TUBE ASSY FUEL	油管組	1	
		17689-KBE-9000	1	TUBE ASSY TANK TO 3 WJT	油管	1	
		19411-KCB-9000	0	CLIP HOSE	管束	2	
		37801-GA7-7000	1	PACKING BASE	墊圈盤	1	
		37802-GA7-7000	2	RET FUEL UNIT	浮筒計承件	1	
		3780A-KKC3-9000	0	FUEL UNIT ASSY	油量指示器組	1	
		50139-KKC4-9000	0	BRKT FUEL PUMP	汽油泵蓋支架	1	
		50197-KKC4-9000	0	STAY FLOOR	踏板支架	1	
		93903-35220	0	SCREW TAPPING 5*12	螺釘 5X12	3	
		94050-06080	0	NUT FLANGE 6MM	螺帽 6MM	6	

F 10 Fuel Tank

油
箱

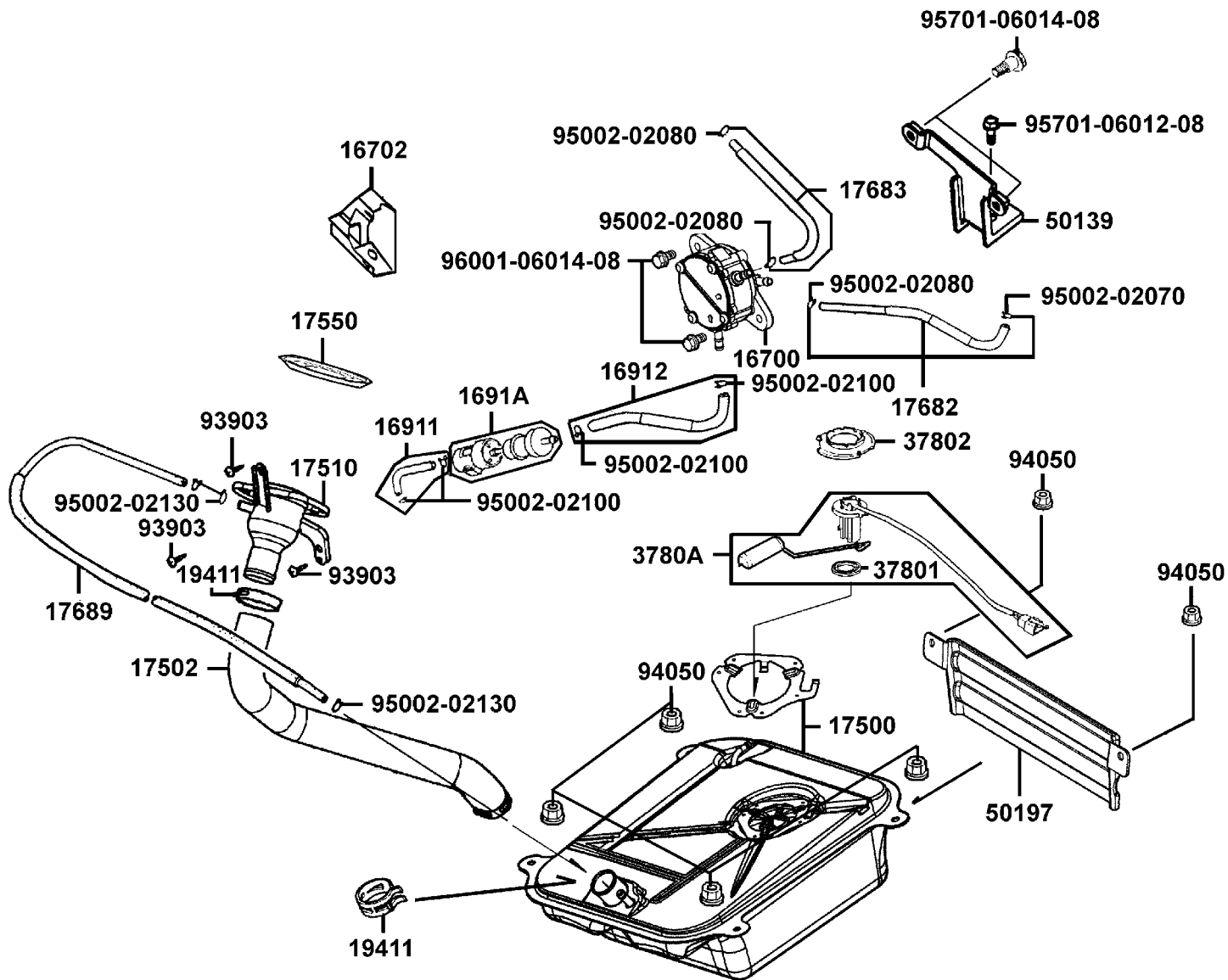

販賣記號 Sales mark	項目 Ref no	零件號碼 Part no	版數 Ver	英文名稱 Description	中文名稱 Chinese	需要用量 Regd no	參考價 Ref Price
		95002-02070	0	CLIP B7 TUBE	管夾	1	
		95002-02080	0	CLIP B8 TUBE	管夾	3	
		95002-02100	0	CLIP B10 TUBE	管夾	4	
		95002-02130	0	CLIP B12.5 TUBE	管夾	3	
		95701-06012-08	0	BOLT FLANGE 6*12	螺絲 6X12	1	
		95701-06014-08	0	BOLT FLANGE 6*14	螺絲 6*14	2	
		96001-06014-08	0	BOLT FLANGE 6*14	螺絲 6X14	2	

F 11 Battery

電
瓶

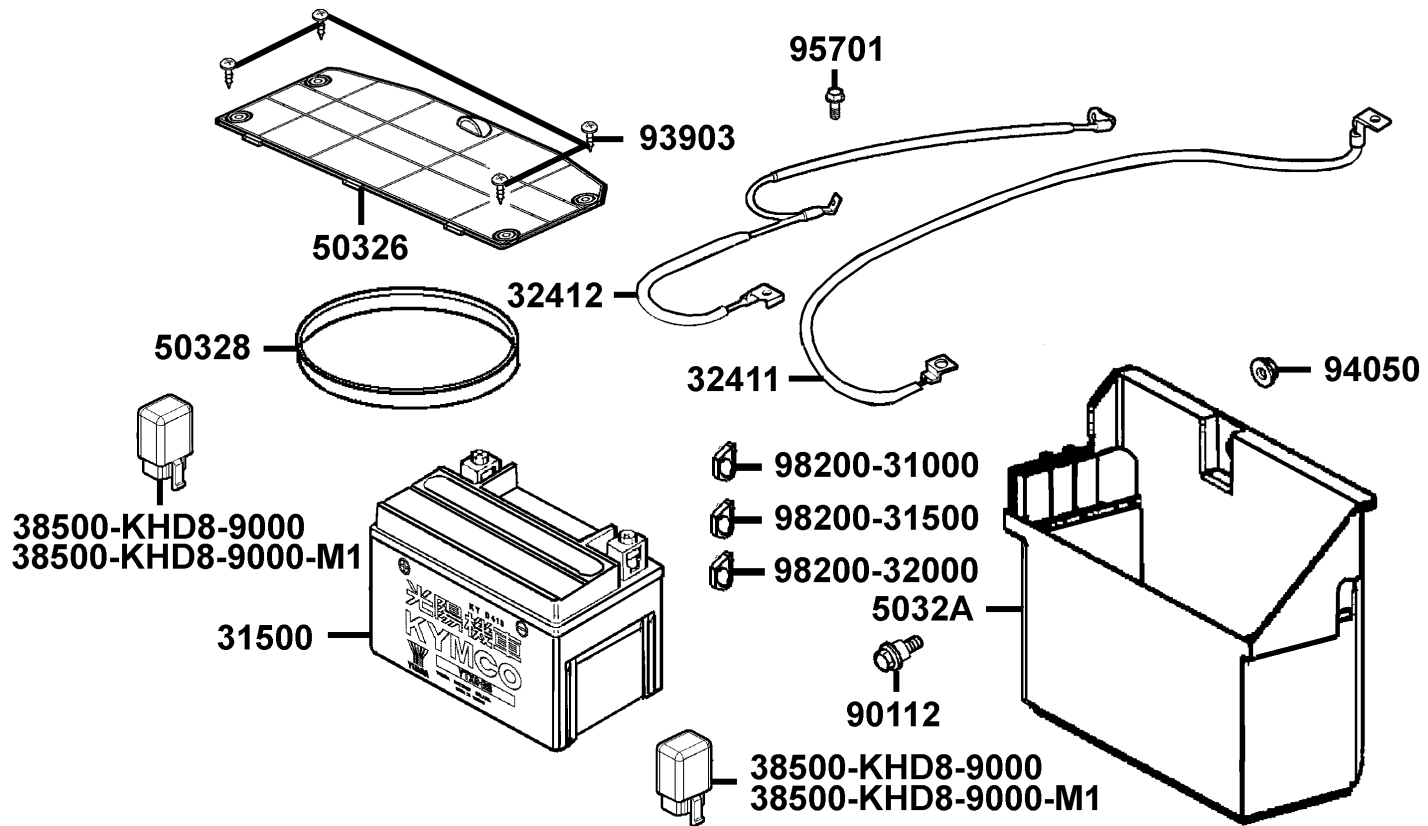

販賣記號 Sales mark	項目 Ref no	零件號碼 Part no	版數 Ver	英文名稱 Description	中文名稱 Chinese	需要用量 Regd no	參考價 Ref Price
		31500-KAF-9000-M1	3	BATTERY YTX9-BS	電池	1	
		32411-KKC4-9000	0	CABLE BATTERY	電池導線	1	
		32412-KKC3-9000	0	CABLE EARTH	電池接地線	1	
		38500-KHD8-9000	0	RELAY ASSY LIGHT	繼電器	2	
		38500-KHD8-9000-M1	0	RELAY ASSY LIGHT	繼電器	2	
**		50326-KKC4-900	0	COVER BATTERY	電池蓋	1	
		50328-KBN-2000	0	BAND BATTERY	電池束帶	1	
		5032A-KKC4-9000	0	CASE ASSY BATTERY	電池箱	1	
		90112-KBN-9010	0	BOLT FLANGE 6MM	螺絲 6MM	1	
		93903-GY6-9000	0	SCREW TAPPING 4*14	螺絲 4*14	4	
		94050-06080	0	NUT FLANGE 6MM	螺帽 6MM	1	
		95701-06012-08	0	BOLT FLANGE 6*12	螺絲 6X12	1	
		98200-31000	0	BLADE FUSE 10A	保險絲10A	1	
		98200-31500	0	BLADE FUSE 15A	保險絲15A	1	
		98200-32000	0	BLADE FUSE 20A	保險絲20A	1	

F 12 Body Cover●Luggage Box

車體蓋 ● 行李箱

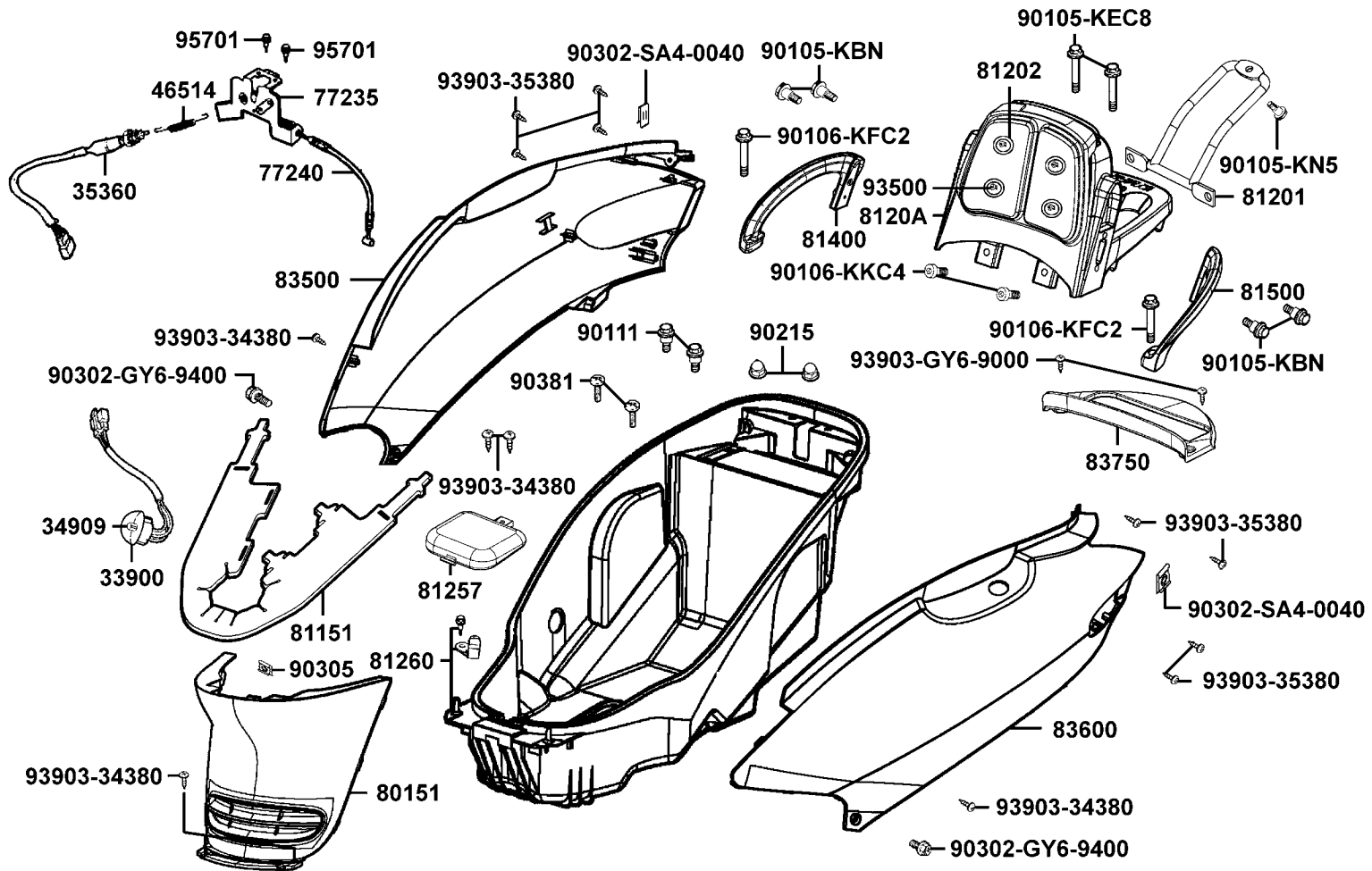

販賣記號 Sales mark	項目 Ref no	零件號碼 Part no	版數 Ver	英文名稱 Description	中文名稱 Chinese	需要用量 Regd no	參考價 Ref Price
		33900-KBF-9000	0	LIGHT ASSY LUGGAGE BOX	行李箱照明燈	1	
		34909-KBF-9000	0	BULB WEDGE BASE	燈泡	1	
		35360-KBF-9000	1	SW UNIT LUGGAGE BOX LIGHT	行李箱燈開關	1	
		46514-KBF-9000	0	SPRING STOP SWITCH	置物架開關彈簧	1	
		77235-KKC4-9000	0	CATCH COMP SEAT	座墊檔器	1	
		77240-KKC4-9000	1	CABLE COMP SEAT LOCK	座墊鎖導線	1	
**		80151-KKC4-900	0	COVER CENTER	中心蓋	1	
		81151-KKC4-9000	0	PLATE HEAT GUARD	防熱板	1	
		81201-KKC4-900	1	POWER BAR RR CARRIER	後架拉柄	1	
		81202-KKC4-900	0	UNBRELLALIKE CLASP	後座座墊連接套筒	4	
		8120A-KKC4-900	6	CARRIER ASSY RR	後架	1	
		81257-KKC4-800	0	COVER CABB MAINT	汽化器保養蓋	1	
		81260-KKC4-9000	1	BOX ASSY LUGGAGE	行李箱組	1	
**		81400-KKC4-900	0	SIDE R GRIP	右握桿	1	
**		81500-KKC4-900	0	SIDE L GRIP	左邊握桿	1	
**		83500-KKC4-900	0	COVER R BODY	車體右邊蓋	1	
**		83600-KKC4-900	1	COVER L BODY	車體左邊蓋	1	
**		83750-KKC4-900	1	COVER RR CENTER	後中心蓋	1	
		90105-KBN-9010	0	BOLT SPECIAL 8MM	螺絲 8MM	4	
		90105-KEC8-9000	0	BOLT WASHER 8MM	螺絲 8MM	2	

F 12

F 12 Body Cover●Luggage Box

車體蓋 ● 行李箱

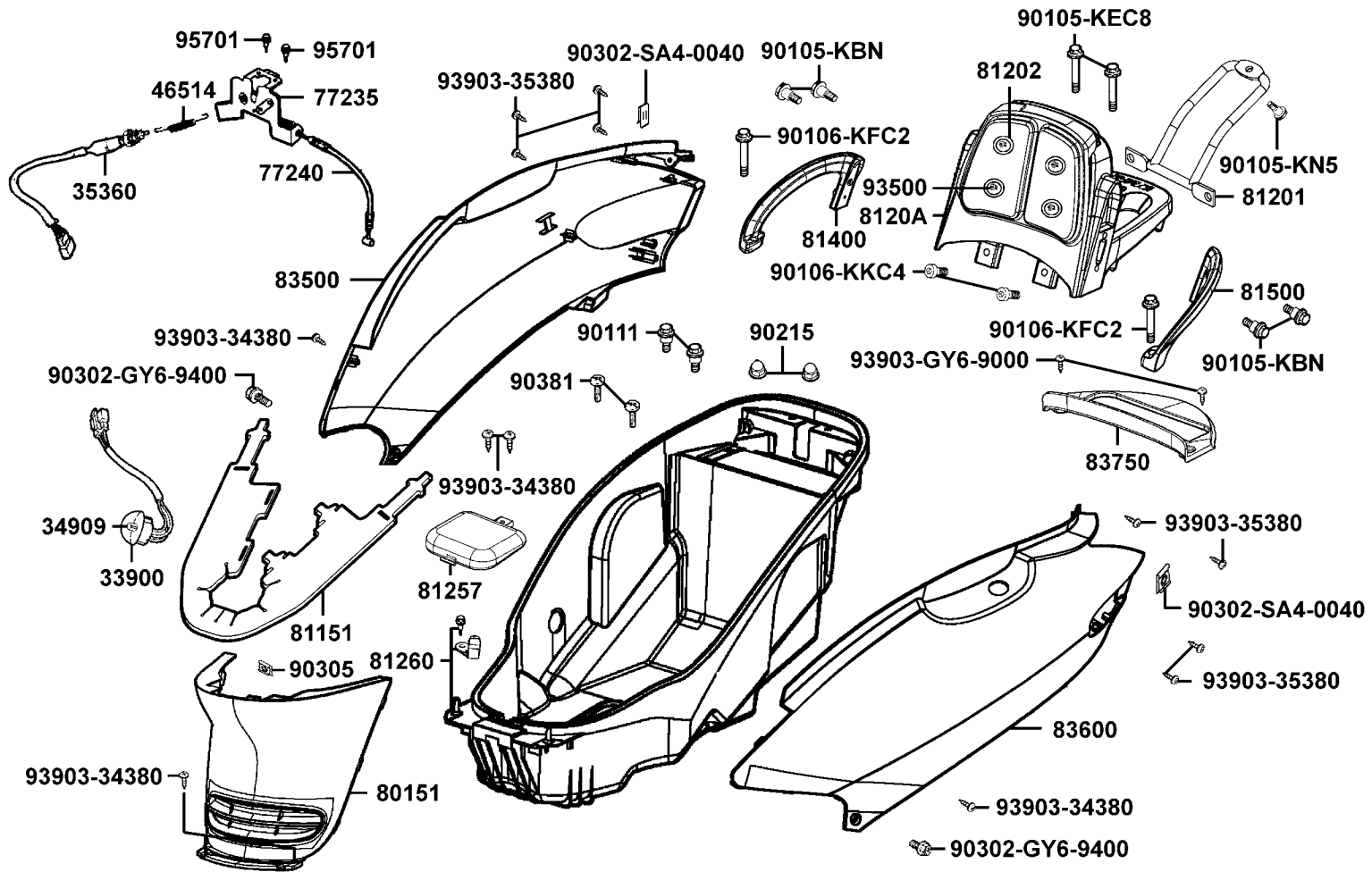

販賣記號 Sales mark	項目 Ref no	零件號碼 Part no	版數 Ver	英文名稱 Description	中文名稱 Chinese	需要用量 Regd no	參考價 Ref Price
		90105-KN5-0010	0	BOLT DISK 6*17	螺絲 6*17	1	
		90106-KFC2-9000	0	BOLT WASHER 8MM	螺絲 8MM	2	
		90106-KKC4-900	0	BOLT WASH 8MM	特殊螺絲 8MM	2	
		90111-187-0000	1	BOLT FLANGE 6MM	螺絲 6MM	2	
		90215-KKC4-900	0	NUT CAP 6MM	螺帽 6MM	2	
		90302-GY6-9400	0	BOLT WASHER 5*16	螺絲 5*16	2	
		90302-SA4-0040	1	NUT SPRING 4MM	夾螺帽 4MM	2	
		90305-GK8-0010	0	NUT CLIP 6MM	夾螺帽 6MM	1	
		90381-GZ5-0010	0	SCREW SPECIAL 6*17	螺絲 6*17	2	
		93500-04012-1A	0	SCREW 4*12	螺絲 4*12	4	
		93903-34380	0	SCREW TAPPING 4*12	螺釘 4*12	6	
		93903-35380	0	SCREW TAPPING 5*16	螺釘 5X16	8	
		93903-GY6-9000	0	SCREW TAPPING 4*14	螺釘 4*14	2	
		95701-06012-08	0	BOLT FLANGE 6*12	螺絲 6X12	2	

F 13 Air Cleaner

空氣濾清器

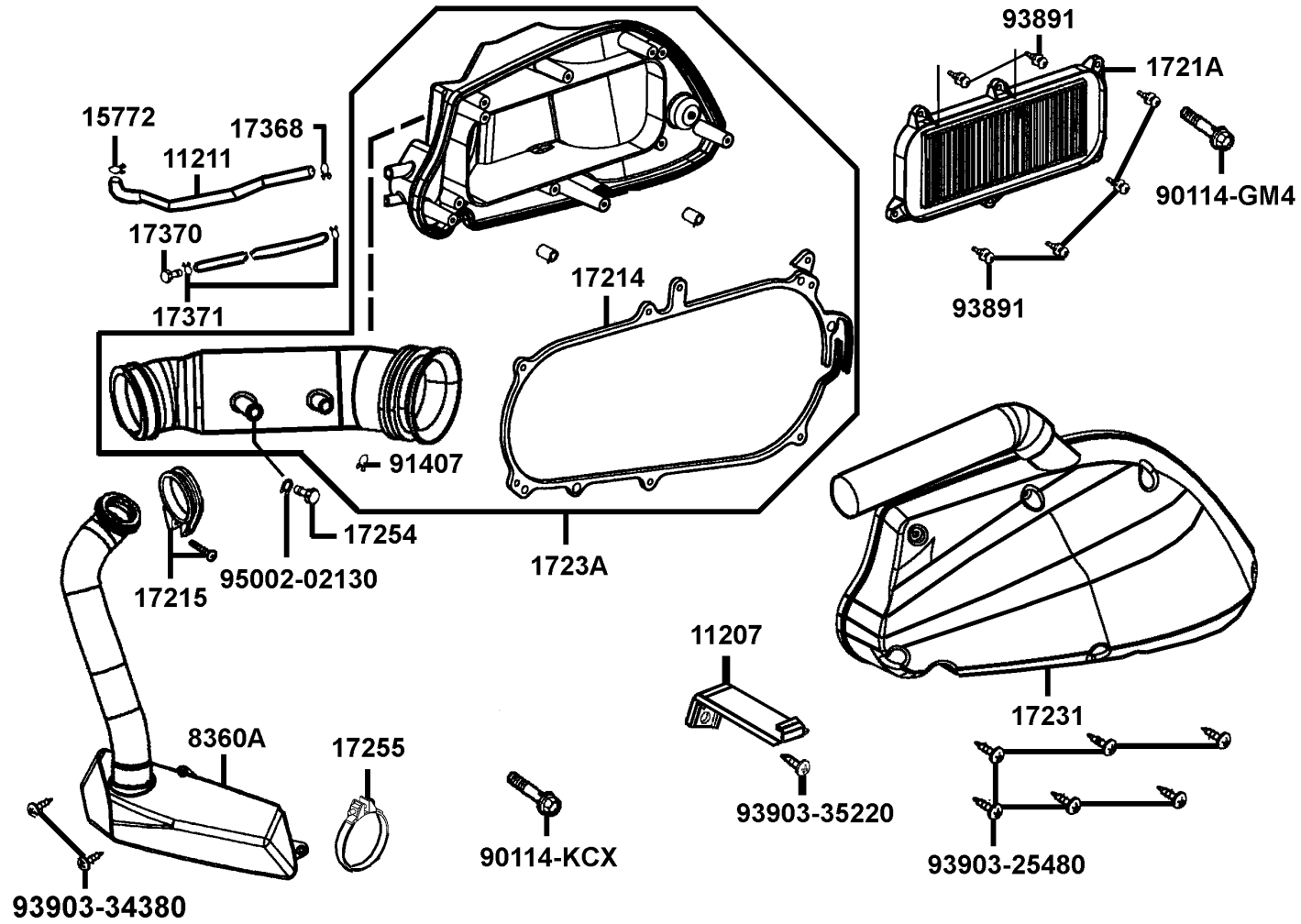

販賣記號 Sales mark	項目 Ref no	零件號碼 Part no	版數 Ver	英文名稱 Description	中文名稱 Chinese	需要用量 Regd no	參考價 Ref Price
		11207-KKC4-9000	3	STAY RR FENDER	後土除支架	1	
		11211-KKC2-900	1	TUBE MISSION BREATHER	通氣管	1	
		15772-500-0130	1	CLIP B14.5 TUBE	管夾	1	
		17214-KKC3-9000	0	SEAL AIR/C COVER	空氣濾清器蓋油封	1	
		17215-KGBG-9000	0	CLIP ASSY AIR/C DUCT	固定管夾	1	
		1721A-KKC3-9000	1	ELEMENT ASSY AIR/C	空氣濾清海綿組	1	
		17231-KKC3-900	1	COVER COMP AIR/C	空氣濾清器蓋組	1	
		1723A-KKC3-E000	2	CASE ASSY AIR/C	空氣濾清器箱組	1	
		17254-KCA-P000	0	PLUG AIR/C CONN TUBE	管塞	1	
		17255-KV7-6710	0	BAND AIR/C CONN	固定管夾	1	
		17368-KB4-6710	0	CLIP B14.5 TUBE	管夾	1	
		17370-419-7010	0	PLUG BREATHER TUBE	管塞	1	
		17371-174-6700	0	CLIP BREATHER TUBE	通氣管夾	2	
		8360A-KKC4-9000	0	CHAMBER ASSY AIR/C	空氣室組	1	
		90114-GM4-0110	1	BOLT FLANGE 6*28	螺絲 6*28	1	
		90114-KCX-9000	0	BOLT FLANGE 6*42	螺絲 6*42	1	
		91407-SA7-0040	0	CLAMP 17 FUSE HOSE	油管夾	1	
		93891-05016-08	0	SCREW WASHER 5*16	螺絲 5X16	6	
		93903-25480	0	SCREW TAPPING 5*20	螺釘 5*20	6	
		93903-34380	0	SCREW TAPPING 4*12	螺釘 4*12	2	

F 13 Air Cleaner

空氣濾清器

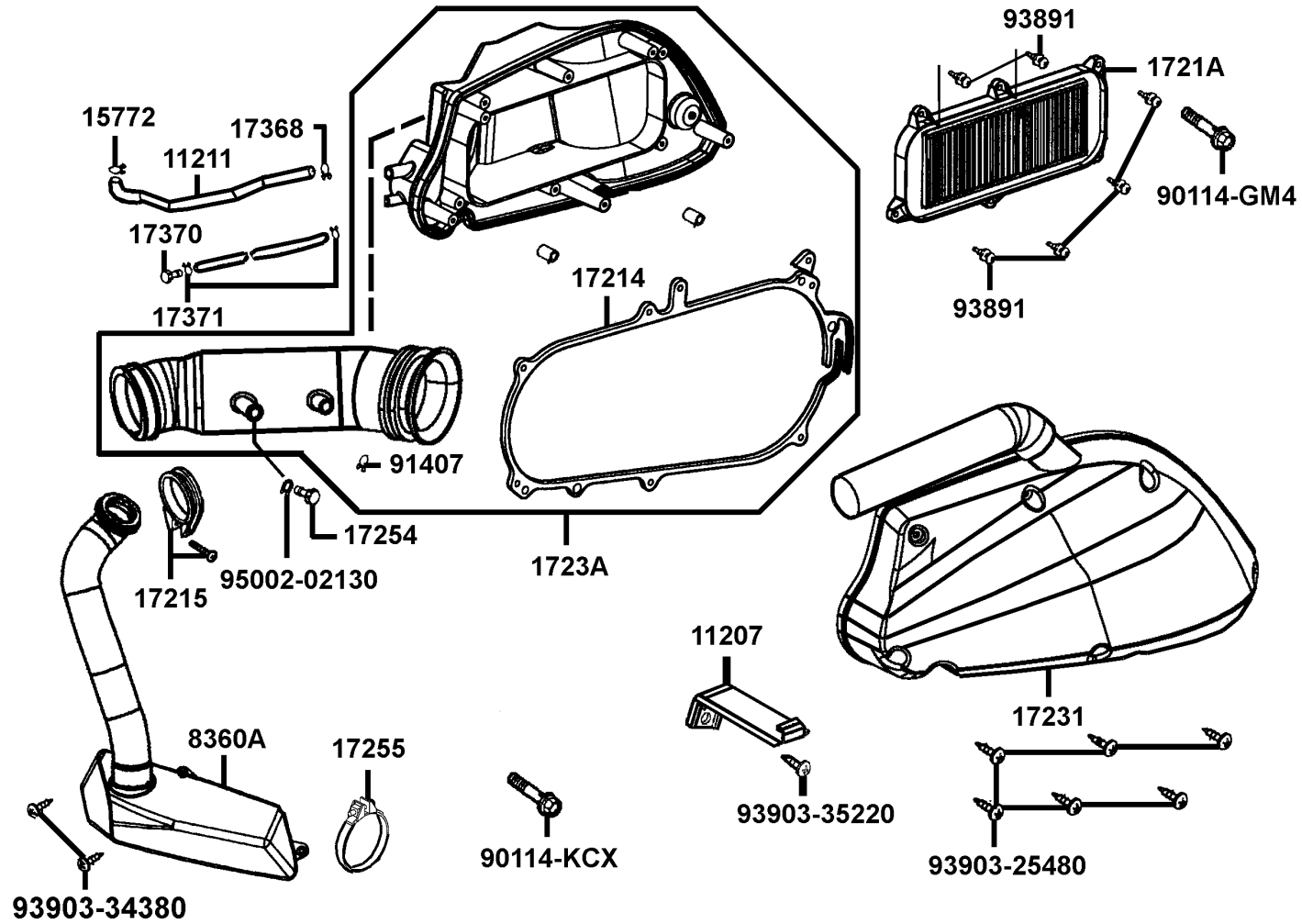

販賣記號 Sales mark	項目 Ref no	零件號碼 Part no	版數 Ver	英文名稱 Description	中文名稱 Chinese	需要用量 Regd no	參考價 Ref Price
		93903-35220	0	SCREW TAPPING 5*12	螺絲 5X12	1	
		95002-02130	0	CLIP B 12.5 TURE	管夾	1	

F 13

F 14 Exhaust Muffler

排
氣
管

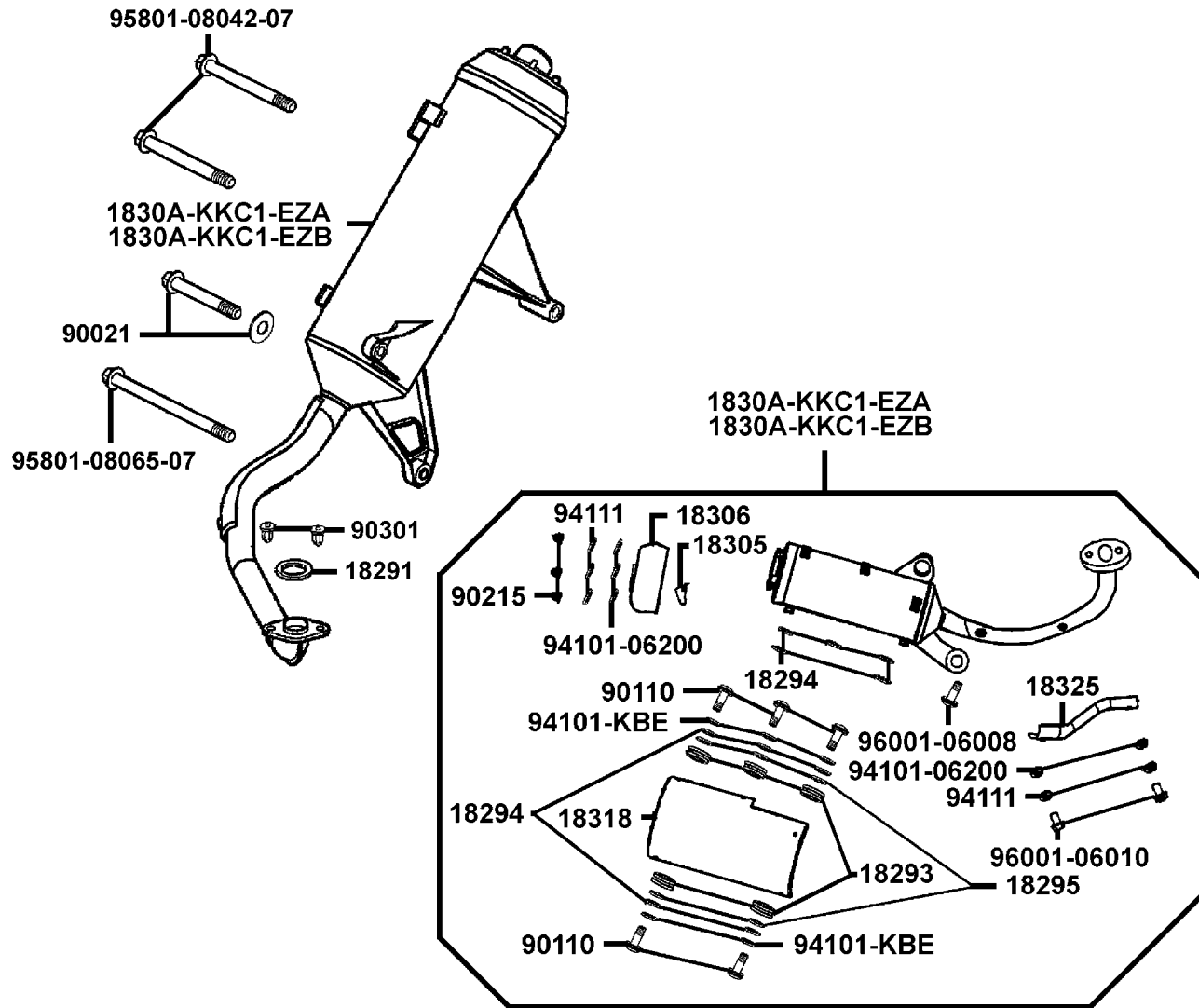

販賣記號 Sales mark	項目 Ref no	零件號碼 Part no	版數 Ver	英文名稱 Description	中文名稱 Chinese	需要用量 Regd no	參考價 Ref Price
		18291-GC8-0000	1	GASKET EXH PIPE	排氣管墊圈	1	
		18293-KCE-9000	0	RUBBER A PROTR	橡皮	5	
		18294-KBE-9000	0	PACKING PROTECTOR	墊片	10	
		18295-KCE-9000	0	COLLAR 6MM	套筒 6MM	5	
		18305-KHD8-9000	0	PROTECTOR TAIL PIPE	排氣管後護板座	1	
		18306-KHD8-9000	0	TAIL CAP MUFFLER	排氣管後護蓋	1	
		1830A-KKC1-EZA	0	MUFFLER ASSY	排氣管組	1	
		1830A-KKC1-EZB	0	MUFFLER ASSY	排氣管組	1	
		18318-KKC1-E000	0	PROTECTOR MUFFLER	排氣管護板	1	
		18325-KKC1-9000	0	PROTECTOR EXH PIPE	排氣管連接板	1	
		90021-GY6-9000	0	BOLT WASHER COMP	螺絲	1	
		90110-KHD8-9000	0	SCREW SPECIAL 6*20	螺絲 6*20	5	
		90215-GM0-9100	0	NUT CAP 6MM	螺帽 6MM	3	
		90301-GY6-9010	1	NUT (HEX) CAP 8MM	圓螺帽 8MM	2	
		94101-06200	0	WASHER PLAIN 6MM	華司 6MM	5	
		94101-KBE-9000	0	WASHER PLAIN 6MM	華司 6MM	5	
		94111-06800	0	WASHER SPG 6MM	彈簧華司 6MM	5	
		95801-08042-07	0	BOLT FLANGE 8*42	螺絲 8*42	2	
		95801-08065-07	0	BOLT FLANGE 8*65	螺絲 8*65	1	
		96001-06008-07	0	BOLT FLANGE SH 6*8	螺絲 6*8	1	

F 14

F 14 Exhaust Muffler

排
氣
管

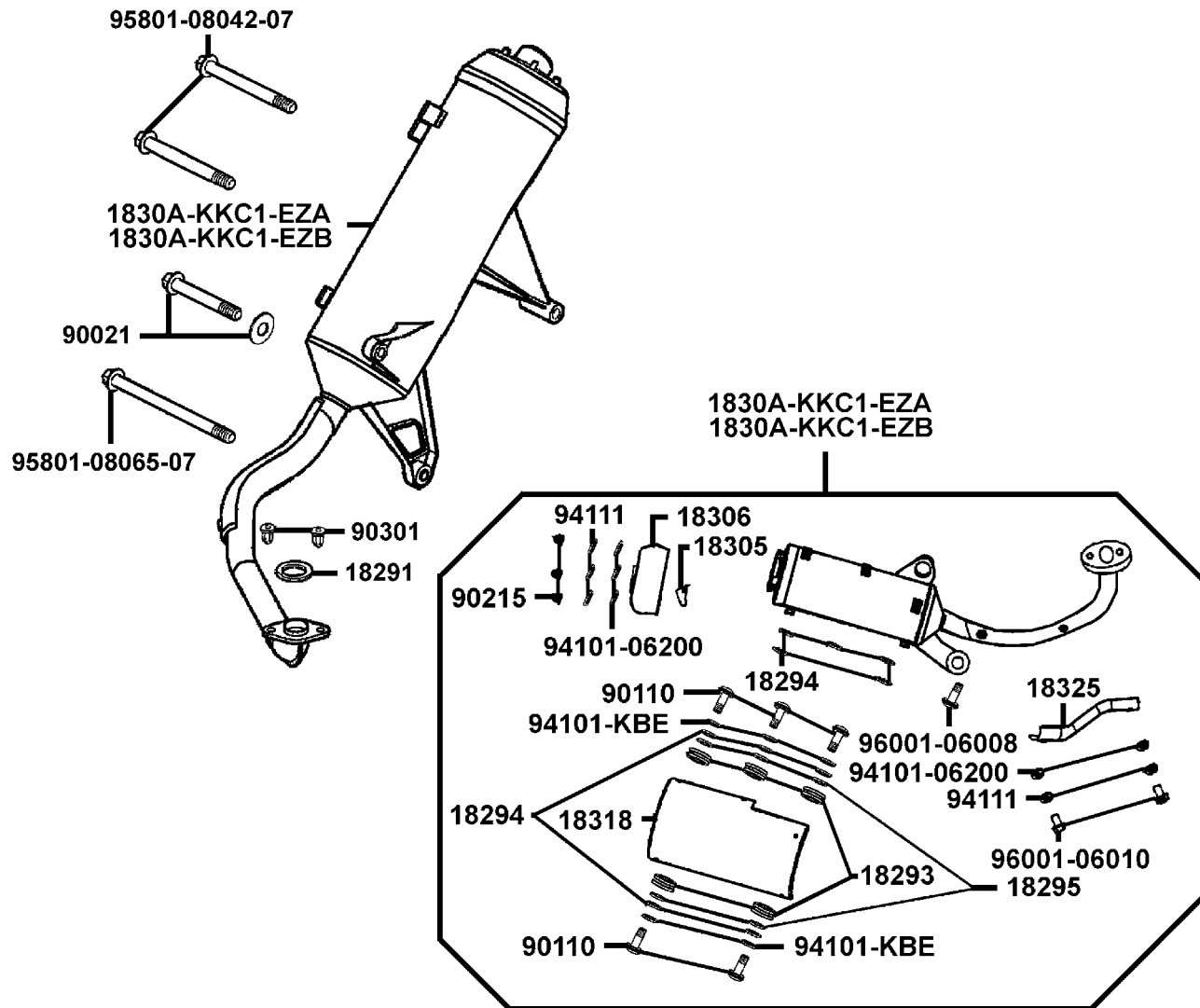

販賣記號 Sales mark	項目 Ref no	零件號碼 Part no	版數 Ver	英文名稱 Description	中文名稱 Chinese	需要用量 Regd no	參考價 Ref Price
		96001-06010-08	0	BOLT FLANGE SH 6*10	螺絲 6*10	2	

F 14

F 15 Stand●Kick Starter Arm

腳架
●
起動踏桿

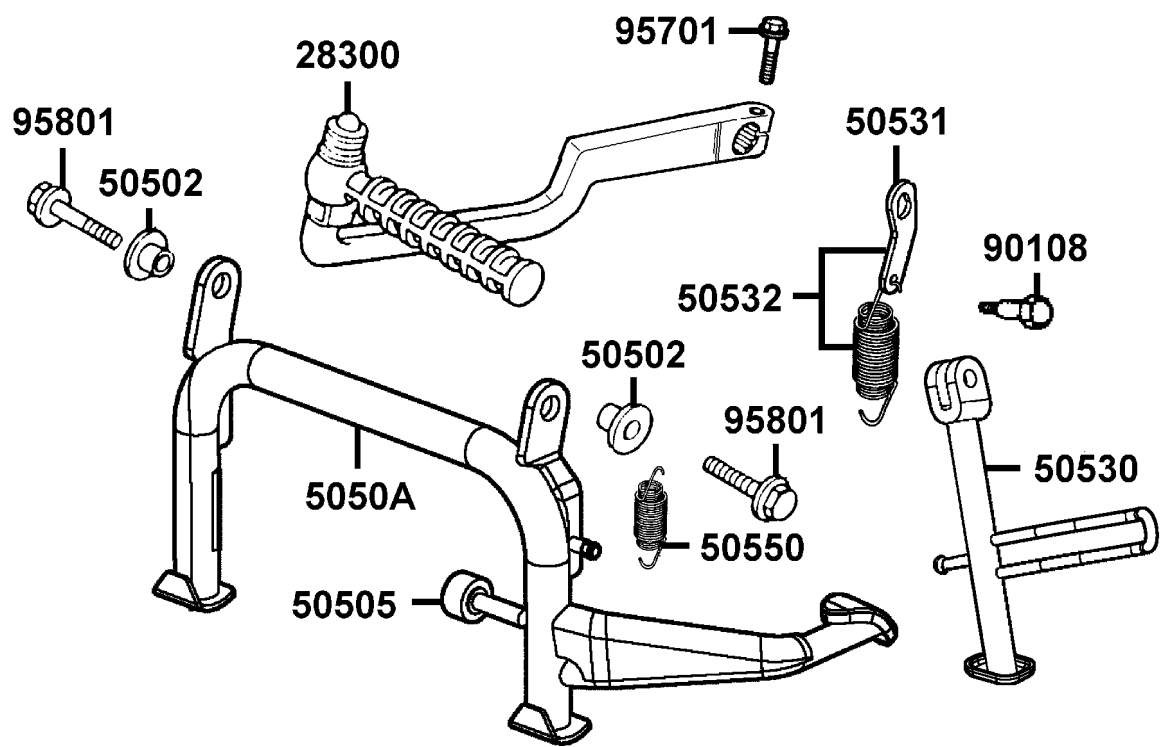

販賣記號 Sales mark	項目 Ref no	零件號碼 Part no	版數 Ver	英文名稱 Description	中文名稱 Chinese	需要用量 Regd no	參考價 Ref Price
		28300-KKC2-E000	0	ARM ASSY KICK STARTER	起動踏桿組	1	
		50502-GY6-9010	0	COLLAR MAIN STAND	主腳架套環	2	
		50505-KKD7-9000	0	RUBBER STOPPER MAIN	主腳架橡皮	1	
		5050A-KKC3-900	5	STAND ASSY MAIN	主腳架組	1	
		50530-KKC4-E00	1	BAR SIDE STAND	側腳架	1	
		50531-KEB7-E000	1	PLATE SPRING STOPPER	彈簧止住板	1	
		50532-KGBG-E000	1	SPRING COMP SIDE STAND	側腳架彈簧	1	
		50550-KEB7-E000	1	SPG ASSY MAIN STAND	主腳架彈簧	1	
		90108-KFC8-E000	0	SCREW SIDE STAND PIVOT	側腳架螺絲	1	
		95701-06022-07	0	BOLT FLANGE 6*22	螺絲 6X22	1	
		95801-10025-08	0	BOLT FLANGE 10*25	螺絲 10*25	2	

F 15

F 16 Rear Cushion

後
避
震
器

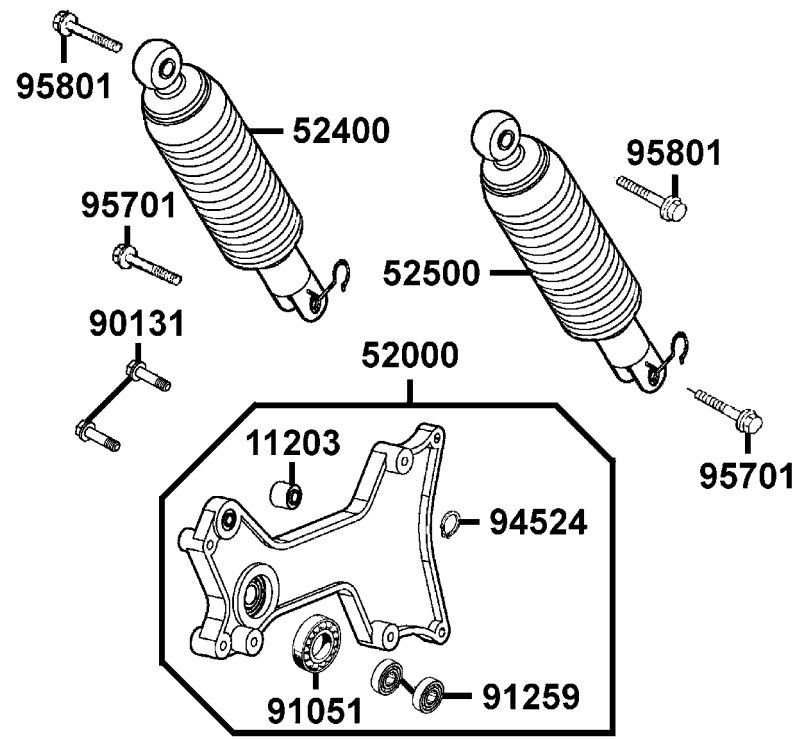

販賣記號 Sales mark	項目 Ref no	零件號碼 Part no	版數 Ver	英文名稱 Description	中文名稱 Chinese	需要用量 Regd no	參考價 Ref Price
		11203-GC7-3010	2	UNDER RUBBER BUSH RR CUSHION	後緩衝下襯套	1	
**		52000-KKC3-900	2	FORK ASSY REAR	後叉組	1	
**		52400-KKC2-E00	2	CUSHION ASSY R RR	後右避震器	1	
**		52500-KKC2-E00	3	CUSHION ASSY L RR	後左避震器	1	
		90131-KAF-9000	0	BOLT FLANGE 8*42	螺絲 8*42	2	
		91051-KBF-901	0	BRG BALL RAKIAL 6203LLU	軸承 6203	1	
		91259-KBF-9000	0	SEAL OIL	油封	2	
		94524-42000	0	CIR CLIP IN 42	環夾	1	
		95701-08030-08	0	BOLT FLANGE 8*30	螺絲 8*30	2	
		95801-10035-08	0	BOLT FLANGE10*35	螺絲 10*35	2	

F 16

F 17 Front Winker

前
方
向
燈

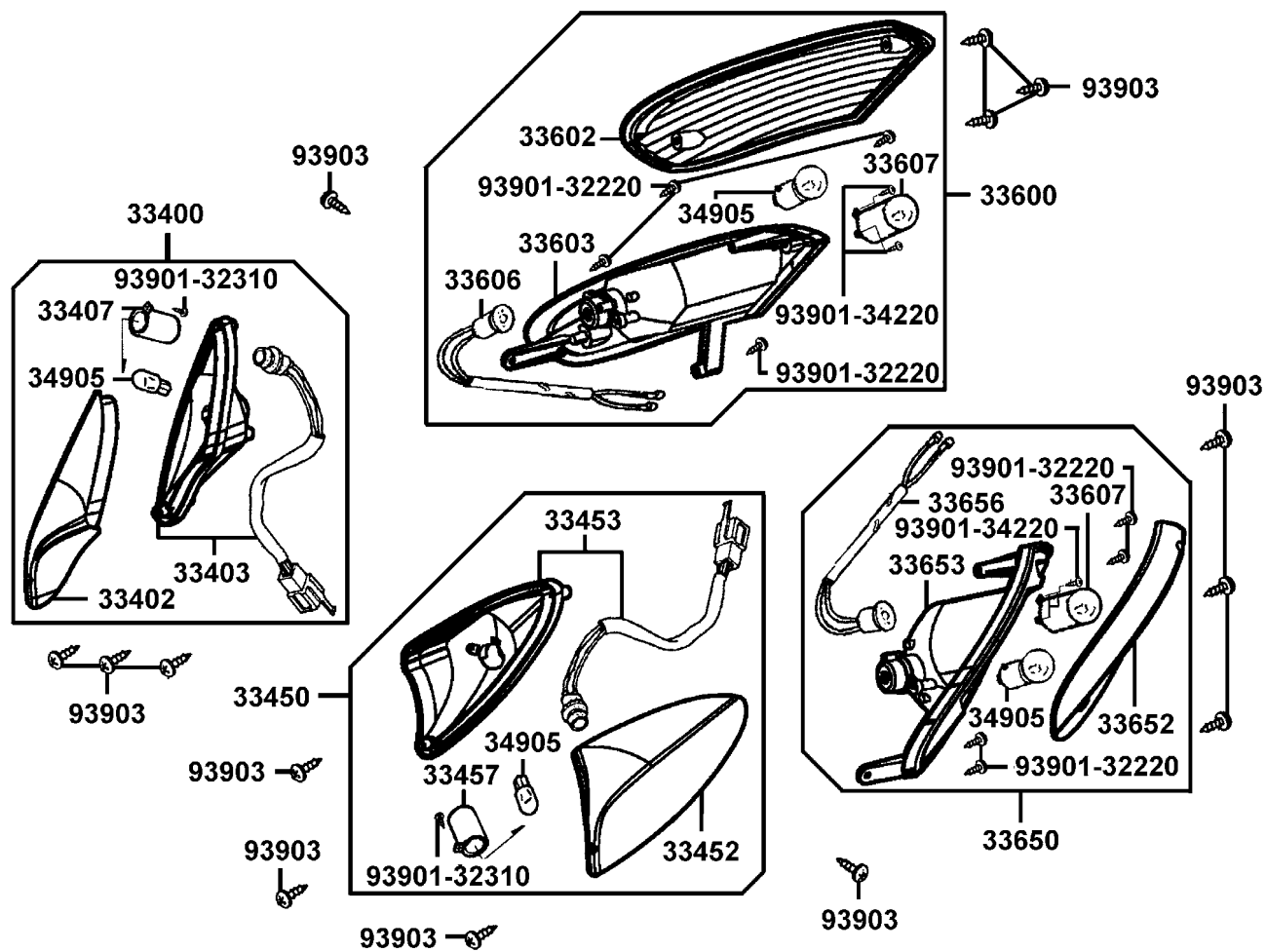

販賣記號 Sales mark	項目 Ref no	零件號碼 Part no	版數 Ver	英文名稱 Description	中文名稱 Chinese	需要用量 Regd no	參考價 Ref Price
		33400-KKC4-E000	0	WINKER ASSY R FR	右前方向燈組	1	
		33402-KKC4-E000	0	LENS FR WINKER R	右前方向燈殼	1	
		33403-KKC4-E000	0	BASE COMP R FR WINKER	右前方向燈座	1	
		33407-KKC4-E000	0	INNER LENS WINKER R	右前方向燈內燈殼	1	
		33450-KKC4-E000	0	WINKER ASSY L FR	左前方向燈組	1	
		33452-KKC4-E000	0	LENS L FR WINKER	左前方向燈殼	1	
		33453-KKC4-E000	0	BASE COMP L FR WINKER	左前方向燈座	1	
		33457-KKC4-E000	0	INNER LENS WINKER L	左前方向燈內燈殼	1	
		33600-KKC4-E000	2	WINKER ASSY R RR	右後方向燈組	1	
		33602-KKC4-E000	0	LENS R RR WINKER	右後方向燈殼	1	
		33603-KKC4-E000	0	BASE R RR WINKER	右後方向燈座	1	
		33606-KKC4-E000	0	SOCKET COMP R RR WINKER	右後方向燈配線	1	
		33607-KKD7-E000	0	INNER LENS WINKER	後方向燈內燈殼	2	
		33650-KKC4-E000	1	WINKER ASSY L RR	左後方向燈組	1	
		33652-KKC4-E000	0	LENS L RR WINKER	左後方向燈殼	1	
		33653-KKC4-E000	0	BASE L RR WINKER	左後方向燈座	1	
		33656-KKC4-E000	0	SOCKET COMP R/L RR WINKER	左後方向燈配線	1	
		34905-KCP-9000	0	BULB WINKER	方向燈泡	4	
		93901-32220	0	SCREW TAPPING 3*10	螺絲 3*10	8	
		93901-32310	0	SCREW TAPPING 3*12	螺釘 3*12	2	

F 17

F 17 Front Winker

前
方
向
燈

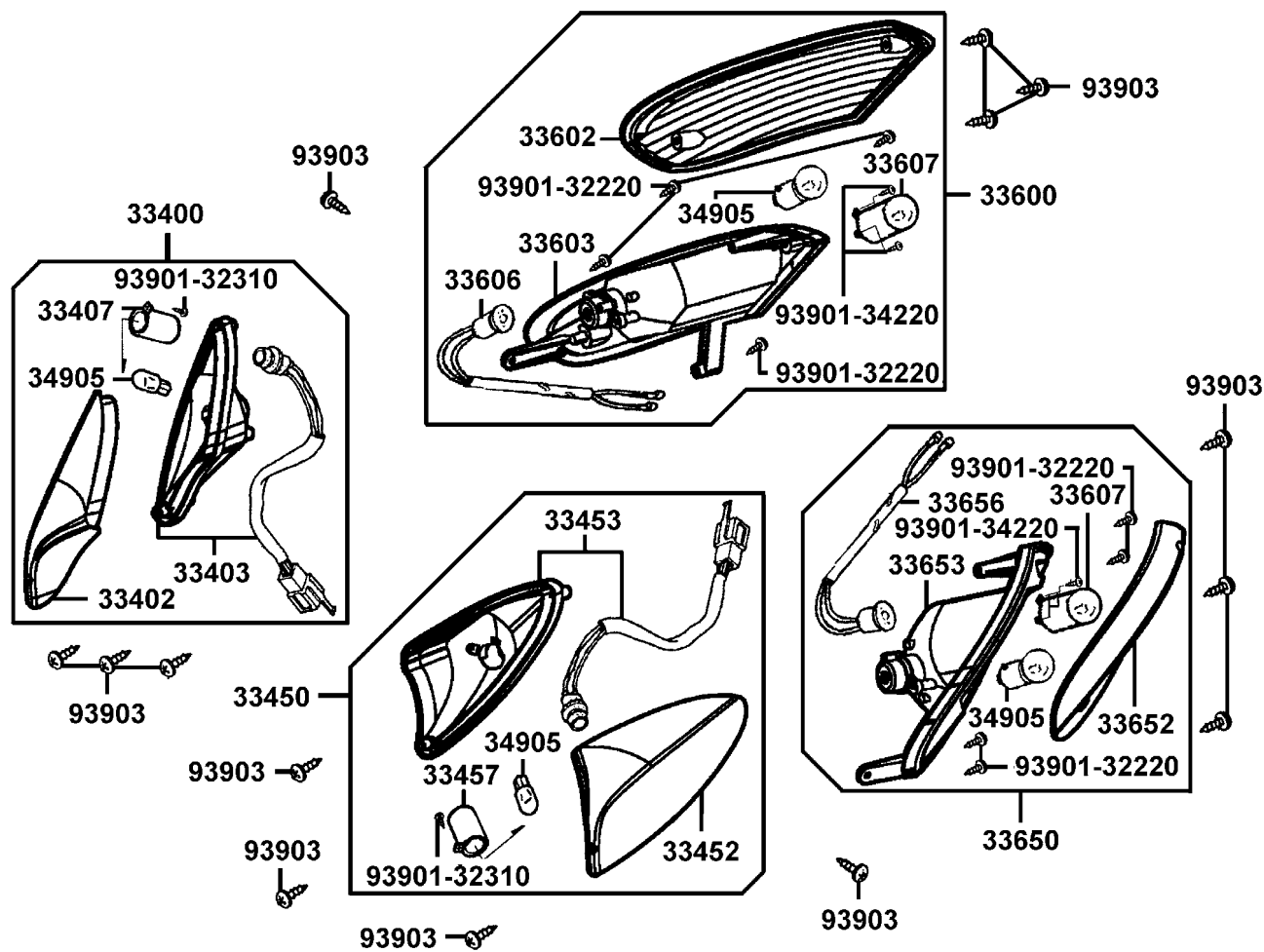

販賣記號 Sales mark	項目 Ref no	零件號碼 Part no	版數 Ver	英文名稱 Description	中文名稱 Chinese	需要用量 Regd no	參考價 Ref Price
		93901-34220	0	SCREW TAPPING 4*10	螺絲 4*10	4	
		93903-34380	0	SCREW TAPPING 4*12	螺釘 4*12	14	

F 17

F 18

Rear Light●Rear Fender

後
燈
●
後
土
除

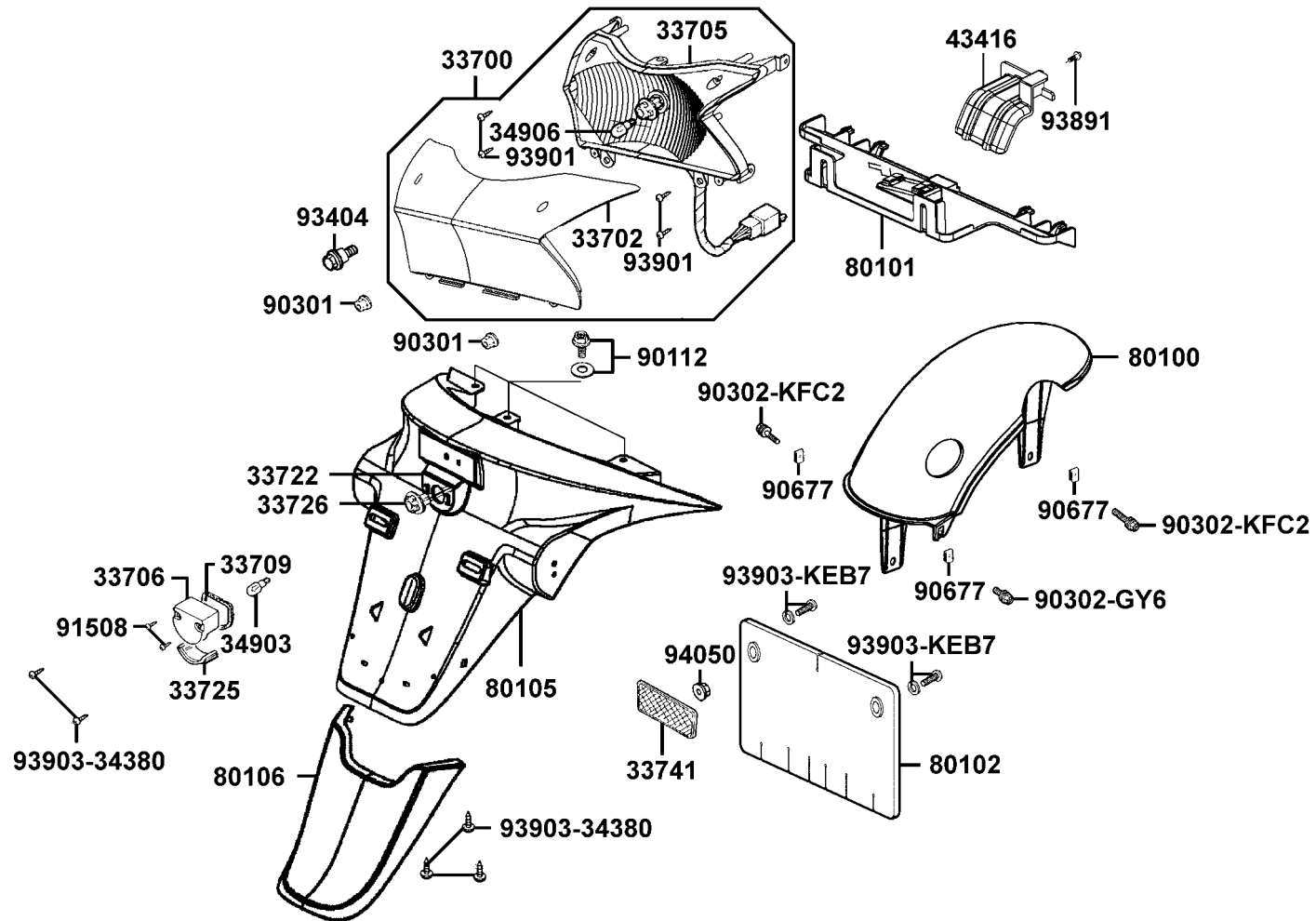

販賣記號 Sales mark	項目 Ref no	零件號碼 Part no	版數 Ver	英文名稱 Description	中文名稱 Chinese	需要用量 Regd no	參考價 Ref Price
		33700-KKC4-E000	0	LIGHT ASSY RR COMB	後燈組	1	
		33702-KKC4-E000	0	LENS TAIL LIGHT	後燈殼	1	
		33705-KKC4-E000	0	BASE COMP TAIL LIGHT	後燈座	1	
		33706-KHB4-E10	0	COVER LICENSE	牌照燈蓋	1	
		33709-KAB-0030	0	PACKING LICENSE	牌照燈蓋墊圈	1	
		33722-KHB4-E000	0	BASE LICENSE	牌照燈座	1	
		33725-KHB4-E000	0	LENS LICENSE	牌照燈殼	1	
		33726-KHB4-E000	0	SOCKET COMP	牌照燈配線	1	
		33741-KBE-9000	0	REFLEX REFLECTOR	反光鏡片	1	
		34903-KCP-9000	0	BULB POSITION	位置燈燈泡	1	
		34906-KCP-9000	0	BULB TAIL & STOP	後燈泡	1	
		43416-KKC4-900	0	GUARD RR CALIPER	後煞車卡鉗護蓋	1	
		80100-KKC4-900	3	FENDER RR TIRE	後輪上土除	1	
		80101-KKC4-900	1	FENDER RR UP	後上土除	1	
		80102-KKC4-900	2	PLATE C SPLASH GUARD	防濺板C	1	
		80105-KKC4-9000	1	FENDER RR	後土除	1	
		80106-KKC4-9000	0	FENDER B RR	後土除B	1	
		90112-KBN-9010	0	BOLT FLANGE 6MM	螺絲 6MM	3	
		90301-634-6700	0	NUT FLANGE 6MM	螺帽 6MM	2	
		90302-GY6-9400	0	BOLT WASHER 5*16	螺絲 5*16	1	

F 18

Rear Light●Rear Fender

後
燈
●
後
土
除

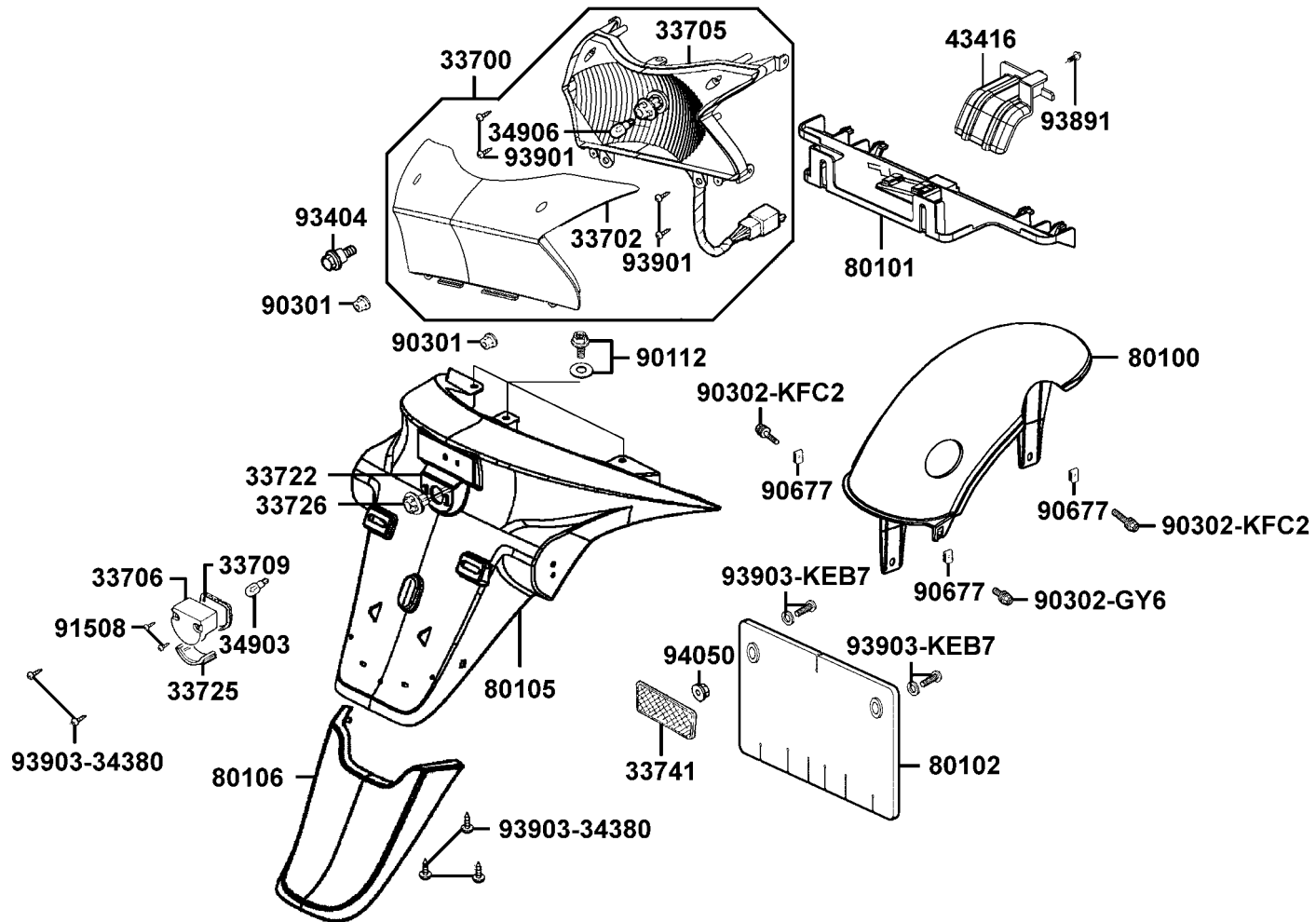

販賣記號 Sales mark	項目 Ref no	零件號碼 Part no	版數 Ver	英文名稱 Description	中文名稱 Chinese	需要用量 Regd no	參考價 Ref Price
		90302-KFC2-9000	0	BOLT WASHER 5*25	螺絲 5*25	2	
		90677-GR1-0030	1	NUT CLIP 5MM	彈簧螺帽 5MM	3	
		91508-KV7-6710-M1	0	SCREW TAPPING 4*14	螺釘 4X14	2	
		93404-06016-07	0	BOLT WASHER 6*16	螺絲 6*16	1	
		93891-05030-07	0	SCREW WASHER 5*30	螺絲 5*30	1	
		93901-34320	0	SCREW TAPPING 4*12	螺釘 4X12	4	
		93903-34380	0	SCREW TAPPING 4*12	螺釘 4X12	5	
		93903-KEB7-9000	0	SCREW WASHER 4MM	螺絲 4MM	2	
		94050-05080	0	NUT FLANGE 5MM	螺帽 5MM	1	

F 18

F 19 Wire Harness

主
電
路
配
線

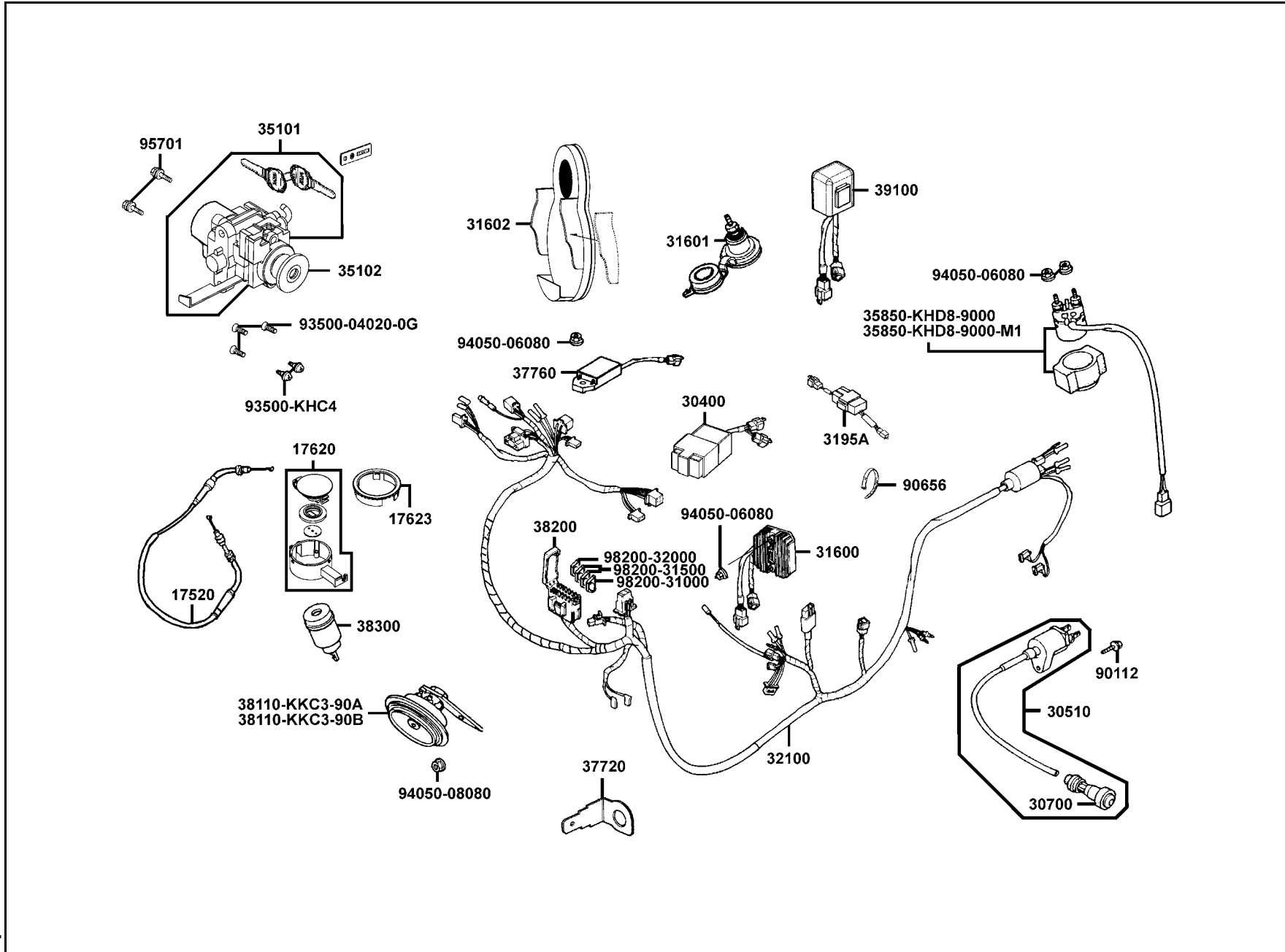

販賣記號 Sales mark	項目 Ref no	零件號碼 Part no	版數 Ver	英文名稱 Description	中文名稱 Chinese	需要用量 Regd no	參考價 Ref Price
		17520-KKC4-9000	0	CABLE COMP FUEL CAP	油箱蓋導線	1	
		17620-KHC5-E000-IT	0	CAP COMP FUEL FILLER	油箱蓋	1	
		17623-KHC4-9000	6	COLLAR FUEL CAP	油箱蓋套筒	1	
		30400-KN7-6710	0	UNIT ASSY CDI	C.D.I.組	1	
		30510-KBE-900	5	COIL COMP IGN	點火線圈	1	
		30700-KN7-6710	2	CAP ASSY NOISE SUPPRESSOR	火星塞蓋	1	
		31600-KM1-009	9	REG REC COMP	整流器	1	
		31601-KKC4-900	3	SOCKET COMP DC12V	手機充電座	1	
		31602-KKC4-9000	0	SOCKET COMP CELL-PHONE	手機固定座	1	
		3195A-KCB-9000	0	HAZARD CNTR ASSY	警示開關組	1	
		32100-KKC2-E000	0	HARNESS WIRE	主配線	1	
		35101-KKC2-325	0	SW SET COMB & LOCK	主開關	1	
		35102-KHC4-9000	2	COLLAR MAIN SW	主開關指示器套筒	1	
		35850-KHD8-9000	1	SET START MAG	起動開關組	1	
		35850-KHD8-9000-M1	0	SET START MAG	起動開關組	1	
		37720-KGBG-E000	0	EARTH TERMINAL HEATER	接地板	1	
		37760-KGBG-E100	0	UNIT HEATER CONTROL	加熱控制器	1	
		38110-KKC3-90A	1	HORN COMP	喇叭	1	
		38110-KKC3-90B	1	HORN COMP	喇叭	1	
		38200-KHE7-9000	0	BOX COMP FUSE	保險絲空盒	1	

F 19

F 19 Wire Harness

主
電
路
配
線

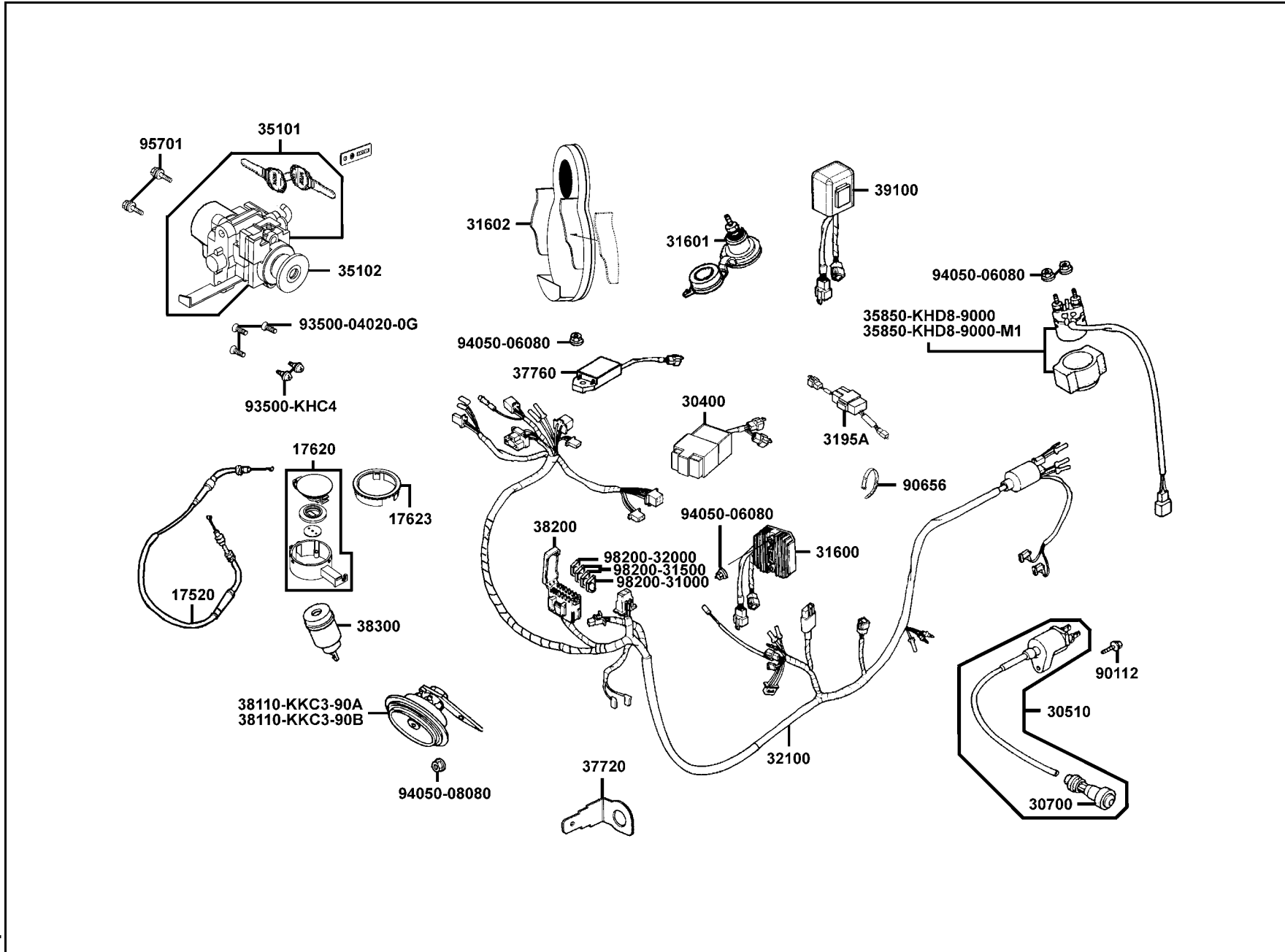

販賣記號 Sales mark	項目 Ref no	零件號碼 Part no	版數 Ver	英文名稱 Description	中文名稱 Chinese	需要用量 Regd no	參考價 Ref Price
		38300-KCE-9000	1	RELAY ASSY WINKER	方向燈繼電器	1	
		39100-KHD8-9000	0	EMI FILTER MOTOR	風扇馬達濾波器	1	
		90112-KDR-9000	0	BOLT FLANGE 5*22	螺絲 5*22	1	
		90656-KDU-9000	0	BAND HARNESS WIRE	配線束帶	1	
		93500-04020-0G	0	SCREW PAN 4*20	螺絲 4*20	3	
		93500-KHC4-90A	0	SCREW PAN 5*10	螺絲 5*10	2	
		94050-06080	0	NUT FLANGE 6MM	螺帽 6MM	4	
		94050-08080	0	NUT FLANGE 8MM	螺帽 8MM	1	
		95701-KHC5-E000-IT	3	BOLT TORQUE 8*25	螺絲 8*25	2	
		98200-31000	0	BLADE FUSE 10A	保險絲(插片形) 10A	1	
		98200-31500	0	BLADE FUSE 15A	保險絲(插片形) 15A	2	
		98200-32000	0	BLADE FUSE 20A	保險絲(插片形) 20A	1	

F 20 Frame Body

車體

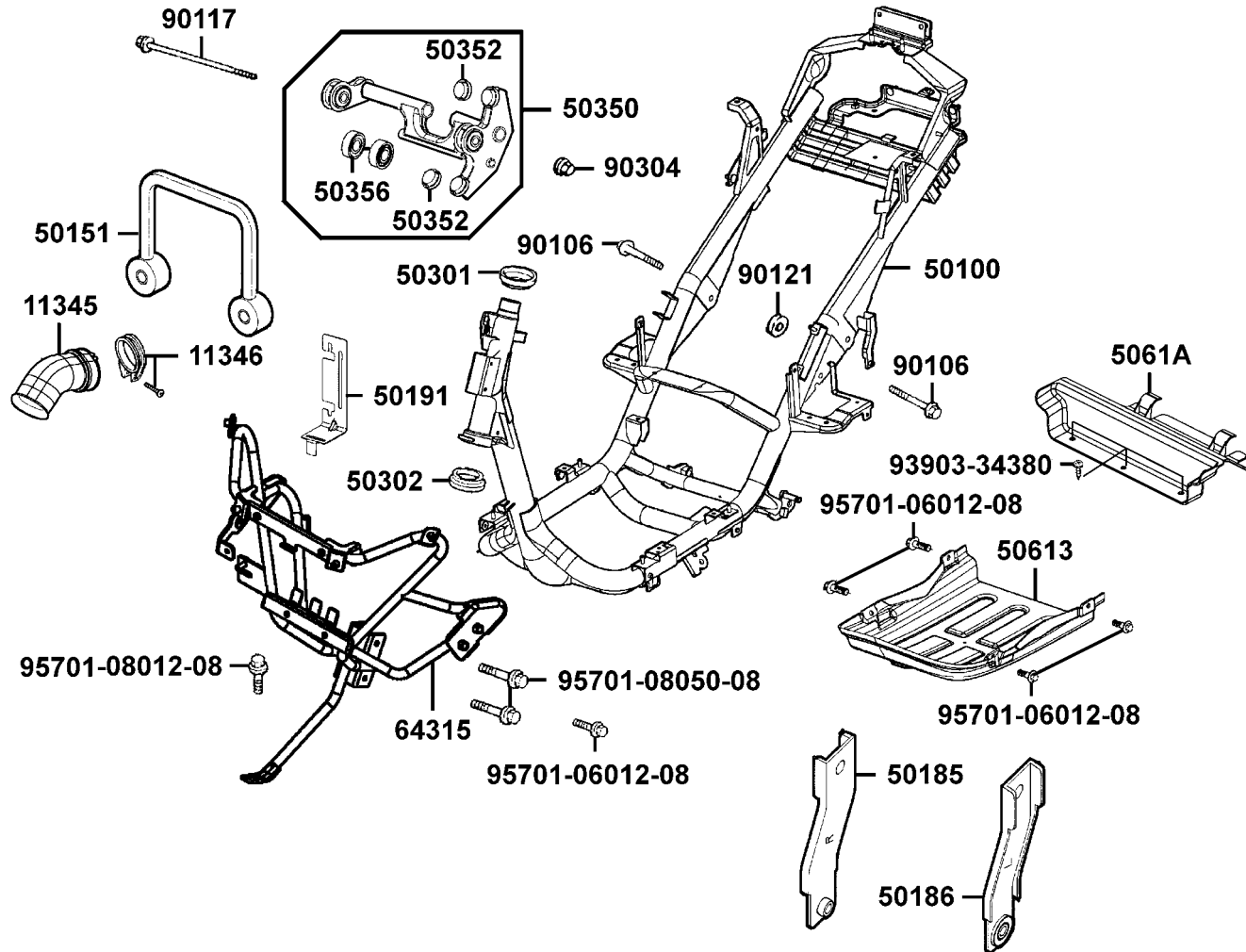

販賣記號 Sales mark	項目 Ref no	零件號碼 Part no	版數 Ver	英文名稱 Description	中文名稱 Chinese	需要用量 Regd no	參考價 Ref Price
		11345-KKC2-E000	0	DUCT L COVER	冷卻導管	1	
		11346-KKC3-900	0	BAND L COVER DUCT	導管束帶	1	
		50100-KKC2-EZ0	0	BODY COMP FRAME	車體	1	
		50151-KKC4-9000	0	HOOK CARRIER	後架座	1	
		50185-KKC4-9000	0	STAY R BODY COVER	車體右邊蓋支柱	1	
		50186-KKC4-9000	0	STAY L BODY COVER	車體左邊蓋支柱	1	
		50191-KKC4-9000	0	STAY ALARM SYSTEM	警示器支架	1	
		50301-KN7-6710	2	RACE UP STRG BALL	上珠碗	1	
		50302-268-0110	0	RACE (STRG BOT) BALL	下珠碗	1	
		50350-KKC3-9000	1	ENG HANGER COMP	引擎吊架	1	
		50352-GY6-9000	0	RUBBER STOPPER	引擎吊架止滑橡皮	2	
		50356-KHE7-E000	0	BUSH SWING LOCK	引擎吊架橡皮襯套	2	
		50613-KKC4-900	1	COVER UNDER	底蓋	1	
		5061A-KKC3-900	1	DEFLECTION UNDER	底蓋延伸板	1	
		64315-KKC4-9000	1	STAY FR COVER	前蓋支架	1	
		90106-KHE7-E000	0	BOLT FLANGE 12*59	螺絲 12*59	2	
		90117-KED9-900	0	BOLT FLANGE 10*265	螺絲 10*265	1	
		90121-KHE7-E000	0	COLLAR DISTANCE	套筒	1	
		90304-GE8-0040	1	NUT U 10MM	螺帽 10MM	1	
		93903-34380	0	SCREW TAPPING 4*12	螺絲 4*12	3	

F 20 Frame Body

車體

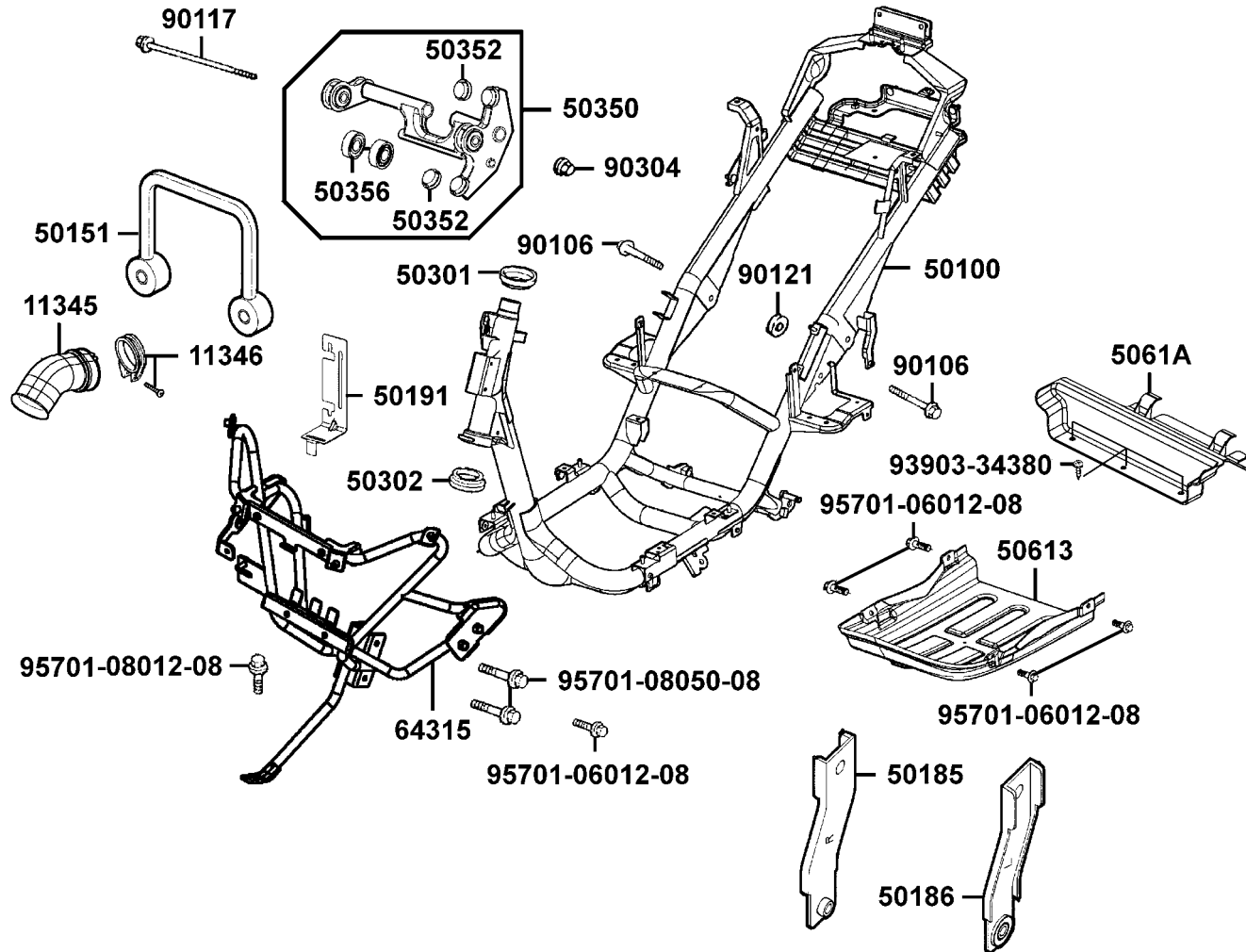

販賣記號 Sales mark	項目 Ref no	零件號碼 Part no	版數 Ver	英文名稱 Description	中文名稱 Chinese	需要用量 Regd no	參考價 Ref Price
		95701-06012-08	0	BOLT FLANGE 6*12	螺絲 6*12	5	
		95701-08012-08	0	BOLT FLANGE 8*12	螺絲 8*12	1	
		95701-08050-08	0	BOLT FLANGE 8*50	螺絲 8*50	2	

F 21 Radiator

水桶

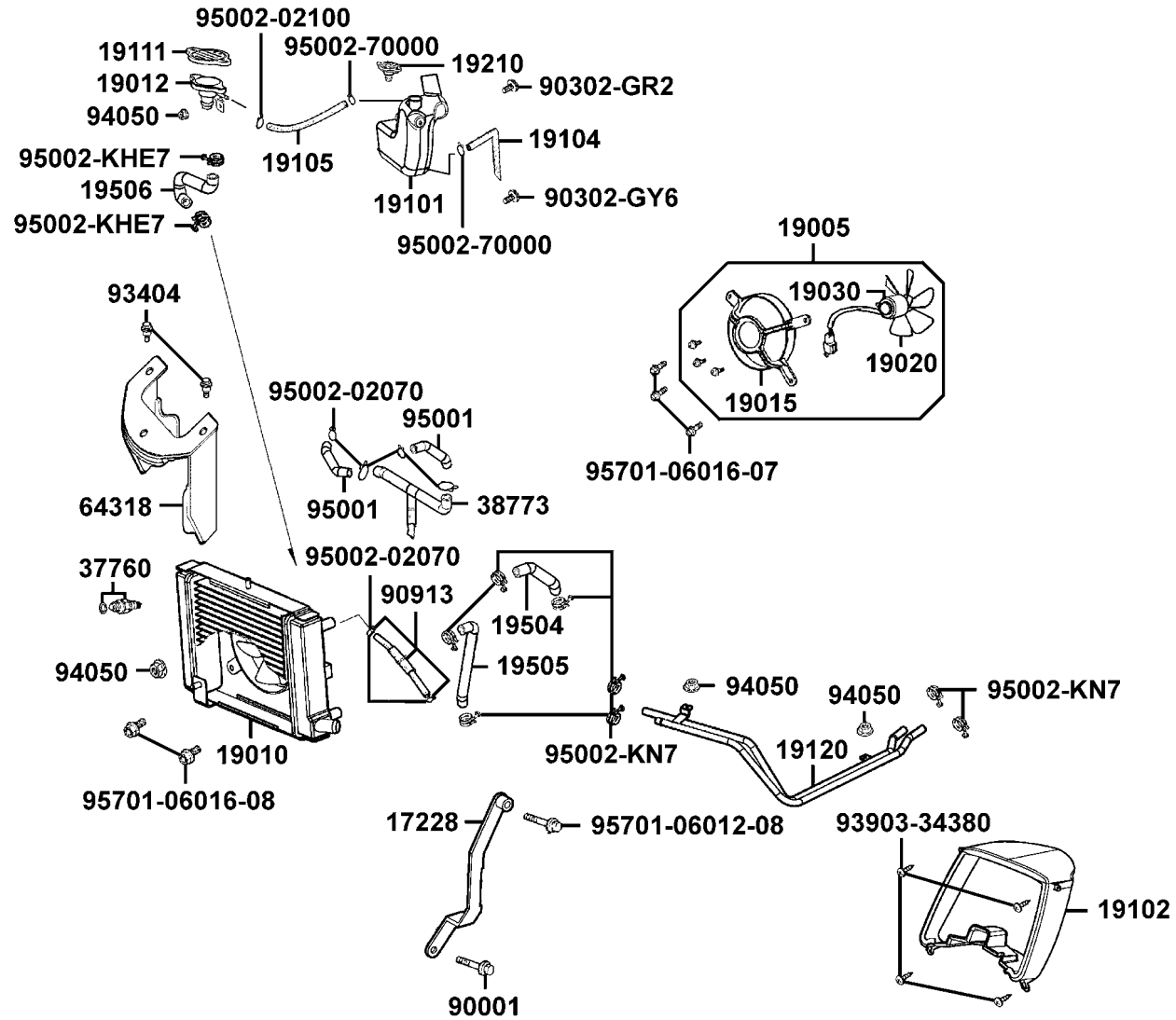

販賣記號 Sales mark	項目 Ref no	零件號碼 Part no	版數 Ver	英文名稱 Description	中文名稱 Chinese	需要用量 Regd no	參考價 Ref Price
		17228-KKC3-9000	0	STAY A/C	空氣濾清器支架	1	
		19005-KKC4-9000	0	SHROUD ASSY	冷卻風扇組	1	
		19010-KKC4-900	1	RADIATOR COMP	水箱	1	
		19012-KHD8-9000	4	UNIT RADIATOR	減壓蓋	1	
		19015-KKC4-9000	0	SHROUD COMP	風扇覆環	1	
		19020-KED9-900	0	FAN COOLING	風扇	1	
		19030-KHD8-9000	0	MOTOR ASSY FAN	風扇馬達	1	
		19101-KKC4-9000	0	TANK RESERVE	預備水箱	1	
		19102-KKC4-9000	0	DUCT COOLING AIR	入風口	1	
		19104-KKC4-9000	0	HOSE ASSY DRAIN	溢流管	1	
		19105-KKC4-9000	0	HOSE ASSY RESERVE-COOLER	水管	1	
		19111-KED9-900	1	CAP COMP	水箱蓋	1	
		19120-KKC4-900	2	PIPE COMP WATER	水管	1	
		19210-KKC4-9000	0	CAP RESERVE TANK	預備水箱蓋	1	
		19504-KKC4-9000	0	HOSE WATER D RADIATOR-PIPE	水管 D	1	
		19505-KKC4-9000	0	HOSE WATER F PIPE-RADIATOR	水管 F	1	
		19506-KKC4-900	1	HOSE WATER G RADIATOR-UNIT	水管 G	1	
		37760-KHD8-9000	0	SW ASSY THERMO	調溫開關	1	
		38773-PB9-0000	0	JOINT 3 WAY 3.5	三向管接頭	1	
		64318-KKC4-9000	0	STAY METER	儀錶支架	1	

F 21 Radiator

水桶

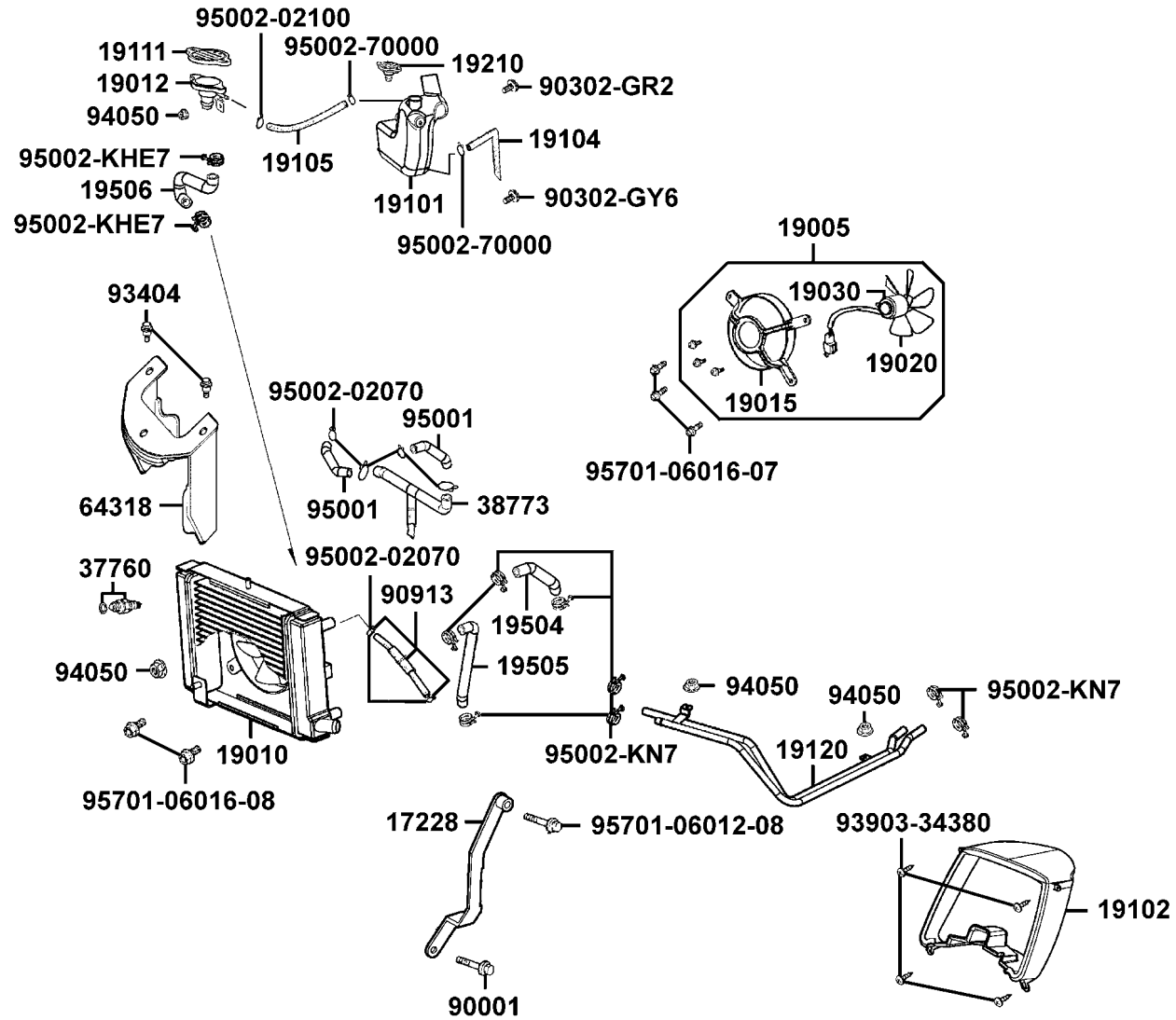

販賣記號 Sales mark	項目 Ref no	零件號碼 Part no	版數 Ver	英文名稱 Description	中文名稱 Chinese	需要用量 Regd no	參考價 Ref Price
		90001-GHB-6610	0	BOLT FLANGE SH 6*22	螺絲 6*22	1	
		90302-GR2-0000	1	BOLT WASH 5*16	螺絲 5*16	1	
		90302-GY6-9010	0	BOLT WASH 5*12	螺絲 5*12	1	
		90913-KKC4-9000	0	TUBE ASSY WATER PUMP TO RAD	水管組	1	
		93404-06016-07	0	BOLT WASHER 6*16	螺絲 6*16	2	
		93903-34380	0	SCREW TAPPING 4*12	螺釘 4*12	4	
		94050-06080	0	NUT FLANGE 6MM	螺帽 6MM	4	
		95001-35225-40	0	TUBE FUEL 3.5*225	通氣管 3.5*225	2	
		95002-02070	0	CLIP B7 TUBE	管夾	6	
		95002-02100	0	CLIP B10 TUBE	管夾	1	
		95002-70000	0	CLIP C11 TUBE	管夾	2	
		95002-KHE7-9000	0	CLIP WATER HOSE	水管夾	2	
		95002-KN7-9100	1	CLIP TUBE	水管夾	8	
		95701-06012-08	0	BOLT FLANGE 6*12	螺絲 6*12	1	
		95701-06016-07	0	BOLT FLANGE 6*16	螺絲 6*16	3	
		95701-06016-08	0	BOLT FLANGE 6*16	螺絲 6*16	2	

F 22 Separated Parts Of Fr Fork

前
叉
附
件

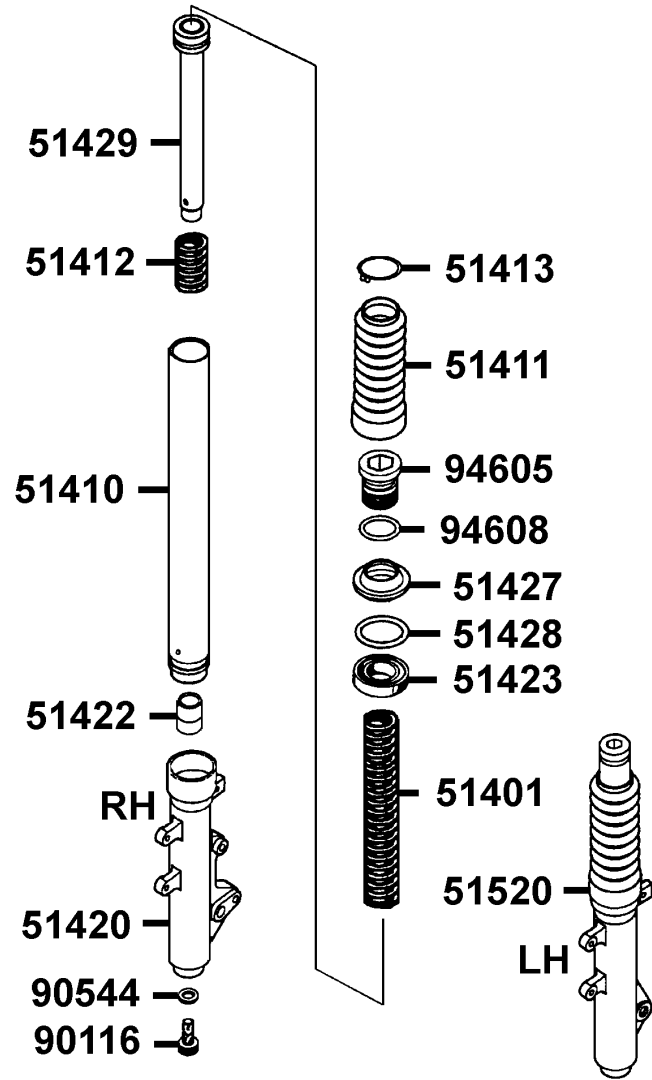

販賣記號 Sales mark	項目 Ref no	零件號碼 Part no	版數 Ver	英文名稱 Description	中文名稱 Chinese	需要用量 Regd no	參考價 Ref Price
		51401-KHD8-9000	0	SPRING	彈簧	2	
		51410-KHD8-9000	0	FORK PIPE COMP	前避震器管	2	
		51411-KHD8-9000	0	BOOT	護套	2	
		51412-KHD8-9000	0	REBOUND SPRING	回位彈簧	2	
		51413-KHD8-9000	0	BOOT BAND	護套夾	2	
		51420-KKC4-9000	0	BOTTOM CASE R	右前避震器底管	1	
		51422-KKC4-900	0	OIL LOCK PIECE	止油接頭	2	
		51423-KAK-9000	0	OIL SEAL	前避震器油封	2	
		51427-KAK-9000	0	DUST SEAL	防塵封	2	
		51428-KAK-9000	0	RING OIL SEAL STOPPER	油封止位環	2	
		51429-KHD8-9000	0	PIPE SEAT COMP	避震管座	2	
		51520-KKC4-9000	0	BOTTOM CASE L	左前避震器底管	1	
		90116-KHD8-9000	0	BOLT	螺絲	2	
		90544-KEC8-9000	0	PACKING	墊片	2	
		94605-KHD8-9000	0	FORK BOLT	螺絲	2	
		94608-30000	0	O RING 23*24	O環 23*24	2	

F 23 Air Cleaner Two

二次空氣濾清器

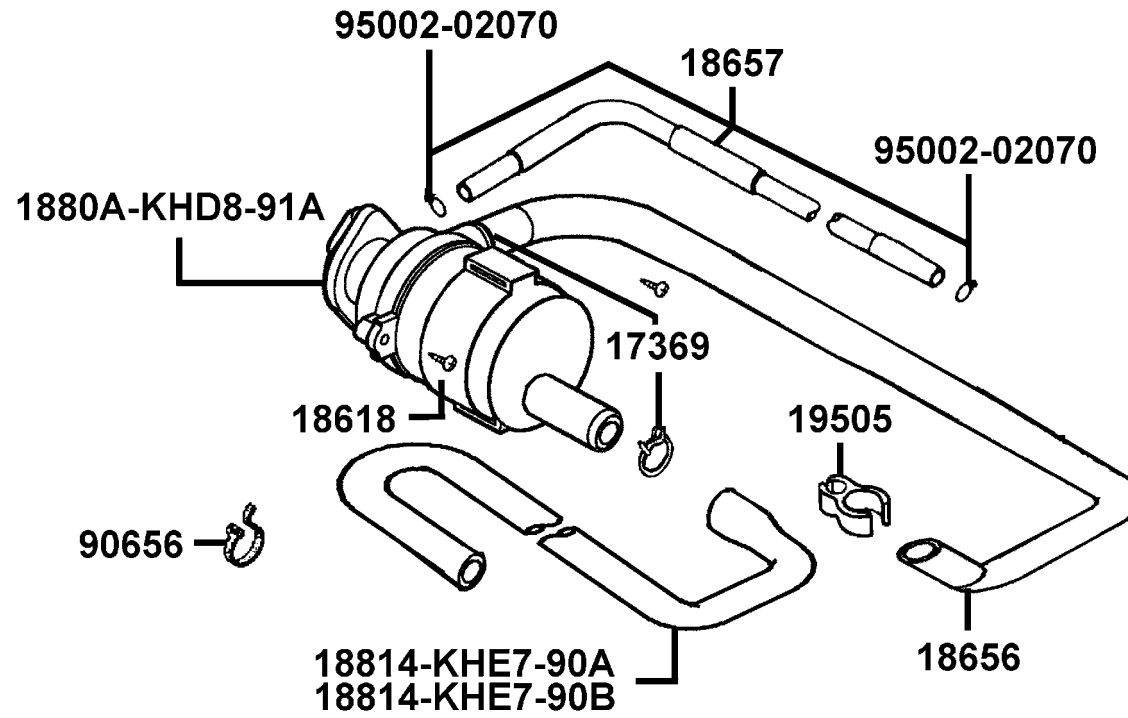

販賣記號 Sales mark	項目 Ref no	零件號碼 Part no	版數 Ver	英文名稱 Description	中文名稱 Chinese	需要用量 Regd no	參考價 Ref Price
		17369-KB4-6700	1	CLIP BREATHER TUBE	通氣管夾	2	
		18618-KHD6-900	0	RUBBER AI CLEANER MOUNT	橡皮	1	
		18656-KKC2-90A	0	DUCT AICV REED VALVE	通氣管	1	
		18657-KKC4-90A	0	TUBE ASSY AICV INLET PIPE	AICV負壓導管	1	
		1880A-KHD8-91A	0	AI/C AICV ASSY	空氣噴射控制閥組	1	
		18814-KHE7-90A	0	DUCT AIR AICV	二次空氣濾清器導管	1	
		18814-KHE7-90B	0	DUCT AIR AICV	二次空氣濾清器導管	1	
		19505-GY6-9400	2	CLAMP A W/H	水管夾	1	
		90656-KDU-9000	0	BAND HARNESS WIRE	配線束帶	1	
		95002-02070	0	CLIP B7 TUBE	管夾	2	

F 24 Caution Label

注意標籤

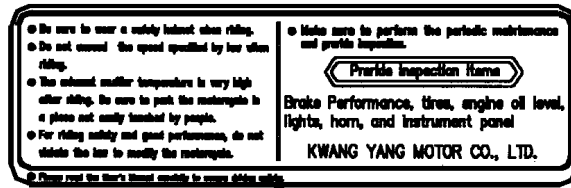

87560

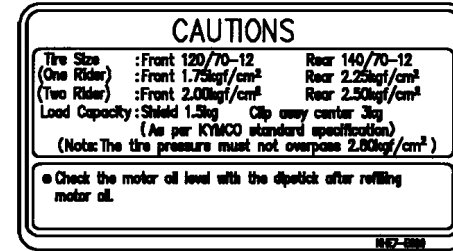

87505

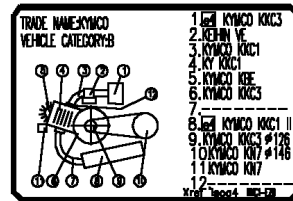

87224

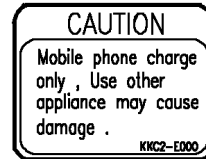

87541-KKC2

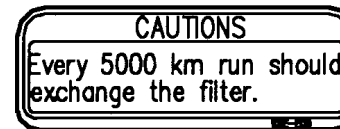

87512

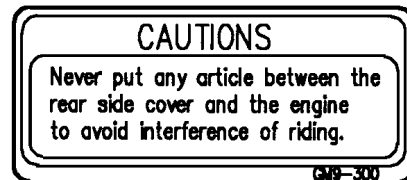

87542

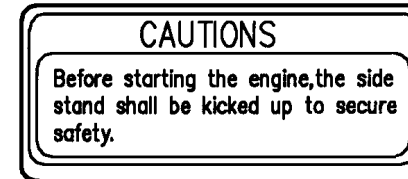

87541-GR1

販賣記號 Sales mark	項目 Ref no	零件號碼 Part no	版數 Ver	英文名稱 Description	中文名稱 Chinese	需要用量 Regd no	參考價 Ref Price
		87224-KKC1-EZ0	0	CAUTION ANTI TAMPERING	貼紙	1	
		87505-KHE7-E00	0	LABEL TIRE	貼紙	1	
		87512-KBE-E00	0	CAUTION FILTER	貼紙	1	
**		87541-GR1-E00	0	CAUTION AUTO SIDE STAND	標籤	1	
		87541-KKC2-E00	0	CAUTION MOBILE PHONE	貼紙	1	
		87542-GR1-E00	1	MARK MAINT CAUTION	貼紙	1	
		87560-GY6-E00	3	MARK DRIVE CAUTION	貼紙	1	

標
徽
●
貼
紙



86202



86212-KKC4



86212-KHD4



87311

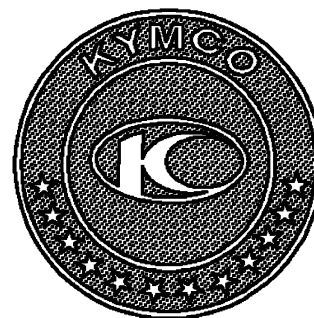

86030

販賣記號 Sales mark	項目 Ref no	零件號碼 Part no	版數 Ver	英文名稱 Description	中文名稱 Chinese	需要用量 Regd no	參考價 Ref Price
**		86030-KKC4-E00	0	EMB HANDLE COVER RR	手柄後蓋標誌	1	
		86202-KKC4-900	0	EMB BODY COVER	車體邊蓋貼紙	2	
		86212-KHD4-E00	0	EMB B BODY COVER	車體邊蓋標誌 B	2	
		86212-KKC4-900	0	EMB B BODY COVER	車體邊蓋貼紙	2	
		87311-KKD6-E00	0	STRIPE MARK EURO 2	EURO 2 標誌	1	



零件號碼索引
PARTS NO. INDEX

零件號碼索引

PART NO. INDEX

零件號碼 PART NO.	版數 VERSION	頁次 PAGE	零件號碼 PART NO.	版數 VERSION	頁次 PAGE	零件號碼 PART NO.	版數 VERSION	頁次 PAGE
			12000			14610-KJ9-0010	0	P-25
0						14711-KBE-9000	1	P-19
0804-E39-0000	0	P-45	12100-KKC1-9000	0	P-25	14721-KAA-9000	3	P-19
			12191-KKC3-9000	0	P-25	14751-KJ9-0030	1	P-19
			12200-KKC1-900	0	P-19	14761-KJ9-0030	1	P-19
10000			12205-KE8-3010	0	P-19	14771-GB4-6800	2	P-19
			12209-GB4-6820-M1	0	P-19	14775-MA6-0000	0	P-19
1001-MA1H-0351	0	P-45	1221A-KBE-9000	1	P-19	14781-MA6-0000-M1	0	P-19
1010-43BH-9900	0	P-45	12251-KED1-9010	0	P-19			
			12310-KBE-9000	4	P-19	15000		
			12361-GY6-9010	0	P-29			
11000			12391-KBE-9000	0	P-19	15100-KKC3-9000	0	P-37
						15133-KM1-0010	0	P-37
11100-KKC1-3050	1	P-15	13000			15141-KJ9-0040	0	P-37
11102-187-0030	3	P-15				1531-803-2000	0	P-45
11192-KKC3-9000	0	P-15	13000-KKC2-900	2	P-25	1531-818-2000	0	P-45
11200-KKC3-3150	0	P-15	13011-GY6-9000	0	P-25	1541A-KKC3-9000	0	P-15
11203-GC7-3010	2	P-15	13101-KED1-9000	0	P-25	15421-107-0000	1	P-29
11203-GC7-3010	2	P-103	13111-384-0010	1	P-25	15421-KKC3-9000	0	P-15
11207-KKC4-9000	3	P-93				15422-KKC3-9000	3	P-15
11211-KKC2-900	1	P-93	14000			15423-KKC3-9000	0	P-15
1122A-KKC2-9000	0	P-31				15426-GE1-9200	0	P-29
11330-KKC3-900	2	P-29	14100-KKC2-220	0	P-19	1565A-KBE-9000	0	P-29
11341-KKC3-900	0	P-15	14401-KDU-9000	0	P-25	15711-KKC3-9000	0	P-37
11345-KKC2-E000	0	P-117	14431-KKC1-9000	0	P-19	15712-KBE-9000	0	P-37
11346-KKC3-900	0	P-117	14450-KBE-9000	0	P-19	15772-500-0130	1	P-93
11383-KDU-9000	0	P-15	14461-KBE-9000	0	P-19			
11384-KHE7-9000	1	P-25	14510-KBE-9000	1	P-25	16000		
11394-KBE-9000	0	P-29	14531-KJ9-0010	0	P-25			
11395-KKC3-9000	0	P-15	14550-KS4-0040-M2	0	P-25	16051-KN7-7410-M1	0	P-45
1198-815-2001	0	P-45	14552-KS4-0030	0	P-25	16075-KG8-9010-M1	0	P-45
			14553-KS4-0030	0	P-25	16076-ND5-0040	0	P-45
			14555-KJ9-0010	0	P-25	16080-KJ9-0030	0	P-45

零 件 號 碼 索 引

PART NO. INDEX

零 件 號 碼 PART NO.	版 數 VERSION	頁 次 PAGE	零 件 號 碼 PART NO.	版 數 VERSION	頁 次 PAGE	零 件 號 碼 PART NO.	版 數 VERSION	頁 次 PAGE
16107-KJ9-0030	0	P-45	17502-KKC4-9000	0	P-83	18814-KHE7-90B	0	P-127
1610K-KKC1-EZ0	0	P-45	17510-KKC4-E000	0	P-83			
16111-KN7-7410-M1	0	P-45	17520-KKC4-9000	0	P-113			
16143-195-7310-M1	0	P-45	17550-KHC4-9000	0	P-83	19000		
16155-ZG8-L100	0	P-45	17620-KHC5-E000-IT	0	P-113			
16163-KCW-0000	0	P-45	17623-KHC4-9000	6	P-113	19005-KKC4-9000	0	P-121
16198-GY6-9000	0	P-45	17682-KKC4-9000	0	P-83	19010-KKC4-900	1	P-121
16217-KBE-9000	1	P-19	17683-KKC4-9000	0	P-83	19012-KHD8-9000	4	P-121
1621-885-2000	0	P-45	17689-KBE-9000	1	P-83	19015-KKC4-9000	0	P-121
1621-886-2000	0	P-45	17910-KKC3-9000	1	P-57	19020-KED9-900	0	P-121
16218-KBE-E000	0	P-19	1795-KG8H-9010	0	P-47	19030-KHD8-9000	0	P-121
16700-KHE7-900	5	P-83				19101-KKC4-9000	0	P-121
16702-KBN-9010	1	P-83				19102-KKC4-9000	0	P-121
16911-KKC4-9000	0	P-83	18000			19104-KKC4-9000	0	P-121
16912-KKC4-9000	0	P-83				19105-KKC4-9000	0	P-121
1691A-KEC2-E000	0	P-83	18291-GC8-0000	1	P-97	19111-KED9-900	1	P-121
			18293-KCE-9000	0	P-97	19120-KKC4-900	2	P-121
17000			18294-KBE-9000	0	P-97	19210-KKC4-9000	0	P-121
			18295-KCE-9000	0	P-97	19211-KKC3-9000	0	P-41
			18305-KHD8-9000	0	P-97	19215-KJ9-0110	0	P-41
1703-GJ2H-0040	0	P-45	18306-KHD8-9000	0	P-97	19217-657-0240	0	P-41
17110-KKC1-E000	0	P-21	1830A-KKC1-EZA	0	P-97	19221-KKC3-9000	0	P-41
17214-KKC3-9000	0	P-93	1830A-KKC1-EZB	0	P-97	19229-KKC3-900	0	P-41
17215-KGBG-9000	0	P-93	18318-KKC1-E000	0	P-97	19231-KBE-9000	2	P-41
1721A-KKC3-9000	1	P-93	18325-KKC1-9000	0	P-97	19300-KE1-0030-M1	1	P-41
17228-KKC3-9000	0	P-121	18601-MJ1-7900	1	P-21	19310-KBE-9000	0	P-41
17231-KKC3-900	1	P-93	18612-KBE-9000	0	P-21	19315-KBE-9000	2	P-41
1723A-KKC3-E000	2	P-93	18618-KHD6-900	0	P-127	19411-KCB-9000	0	P-83
17254-KCA-P000	0	P-93	18645-GY6-9400	0	P-21	19501-KKC3-9000	0	P-41
17255-KV7-6710	0	P-93	18646-GY6-9400	0	P-21	19502-KBE-9000	0	P-25
17368-KB4-6710	0	P-93	18647-KBE-9000	0	P-21	19503-KBE-9000	0	P-41
17369-KB4-6700	1	P-127	18656-KKC2-90A	0	P-127	19504-KKC4-9000	0	P-121
17370-419-7010	0	P-93	18657-KKC4-90A	0	P-127	19505-GY6-9400	2	P-127
17371-174-6700	0	P-93	1880A-KHD8-91A	0	P-127	19505-KKC4-9000	0	P-121
17500-KKC4-9000	1	P-83	18814-KHE7-90A	0	P-127	19506-KKC4-900	1	P-121

零 件 號 碼 索 引

PART NO. INDEX

零 件 號 碼 PART NO.	版 數 VERSION	頁 次 PAGE	零 件 號 碼 PART NO.	版 數 VERSION	頁 次 PAGE	零 件 號 碼 PART NO.	版 數 VERSION	頁 次 PAGE
			23237-KG8-9010	0	P-35	31000		
			23411-KKC3-900	2	P-31			
			23420-KFC8-900	2	P-31	31110-KBE-9000	2	P-41
			23431-KFC8-9000	0	P-31	31110-KBE-9000-M2	0	P-41
21000			23432-KFC8-900	2	P-31	31120-KBE-900	4	P-41
21201-KFC8-3050	0	P-31				31120-KBE-90B	3	P-41
21395-KFC8-9000	0	P-31				31204-KN7-6700	0	P-37
			28000			31205-KN7-6700	0	P-37
						31206-KN7-6700	0	P-37
22000			28101-KJ9-0110	0	P-37	31210-KKC3-9000	0	P-37
22101-KBE-9000	0	P-33	28102-KJ9-0010	0	P-37	31500-KAF-9000-M1	3	P-87
22102-KKC3-9000	0	P-33	28110-KN7-6720	0	P-37	31600-KM1-009	9	P-113
22105-KHD4-E00	1	P-33	28120-KBE-305	0	P-37	31601-KKC4-900	3	P-113
22110-KKC3-9000	0	P-33	28125-426-0010	0	P-37	31602-KKC4-9000	0	P-113
22112-KAA-9000-H1	0	P-33	28126-KDU-900	0	P-37	3195A-KCB-9000	0	P-113
22121-KED1-9000	1	P-33	28131-KN7-6710	0	P-37			
22131-KAA-9000	1	P-33	28211-KFC8-9000	0	P-35			
22132-KN7-6700	3	P-33	28223-KBN-9010	0	P-15	32000		
22300-KN7-6710	2	P-33	28230-KBN-9010	0	P-15			
22350-KN7-6700	0	P-33	28250-KFC8-9000	0	P-15	32100-KKC2-E000	0	P-113
22361-KN7-6710	0	P-33	28253-GN2-6020-M1	0	P-15	32101-KHD8-9000	1	P-41
22401-KN7-6710	0	P-33	28255-GS6-0010	0	P-15	32410-KKC3-9000	0	P-37
22530-KN7-6710	2	P-33	28281-KKC2-9000	0	P-15	32411-KKC4-9000	0	P-87
22804-GB2-0010	0	P-33	28300-KKC2-E000	0	P-101	32412-KKC3-9000	0	P-87
			30000					
			30300-KBE-9000	2	P-41	33000		
23000			30301-KBE-9000-M2	0	P-41			
2301A-KBE-9000	4	P-33	30400-KN7-6710	0	P-113	33100-KKC4-E000	3	P-53
23100-KN7-6720-M1	0	P-33	30510-KBE-900	5	P-113	33120-KKC4-E000	1	P-53
23200-KBE-9000	0	P-33	30700-KN7-6710	2	P-113	33130-KKC4-E000	0	P-53
23220-KN7-6710	0	P-33				33400-KKC4-E000	0	P-105
23225-GC8-0040	0	P-33				33402-KKC4-E000	0	P-105
23226-GC8-0040	0	P-33				33403-KKC4-E000	0	P-105
23233-KN7-6710	0	P-35				33407-KKC4-E000	0	P-105

零件號碼索引

PART NO. INDEX

零件號碼 PART NO.	版數 VERSION	頁次 PAGE	零件號碼 PART NO.	版數 VERSION	頁次 PAGE	零件號碼 PART NO.	版數 VERSION	頁次 PAGE
33450-KKC4-E000	0	P-105				38110-KKC3-90B	1	P-113
33452-KKC4-E000	0	P-105				38200-KHE7-9000	0	P-113
33453-KKC4-E000	0	P-105	35000			38300-KCE-9000	1	P-115
33457-KKC4-E000	0	P-105				38500-KHD8-9000	0	P-87
33600-KKC4-E000	2	P-105	35101-KKC2-325	0	P-113	38500-KHD8-9000-M1	0	P-87
33602-KKC4-E000	0	P-105	35102-KHC4-9000	2	P-113	38773-PB9-0000	0	P-21
33603-KKC4-E000	0	P-105	35102-KHC4-9000-M2	0	P-113	38773-PB9-0000	0	P-121
33606-KKC4-E000	0	P-105	3515A-KKC2-E000	0	P-57			
33607-KKD7-E000	0	P-105	3520A-KBE-9000	2	P-57			
33650-KKC4-E000	1	P-105	35340-KBN-9000	0	P-61	39000		
33652-KKC4-E000	0	P-105	35350-KBN-9000	0	P-61			
33653-KKC4-E000	0	P-105	35360-KBF-9000	1	P-89	39100-KHD8-9000	0	P-115
33656-KKC4-E000	0	P-105	35850-KHD8-9000	1	P-113			
33700-KKC4-E000	0	P-109	35850-KHD8-9000-M1	0	P-113			
33702-KKC4-E000	0	P-109				40000		
33705-KKC4-E000	0	P-109						
33706-KHB4-E10	0	P-109	37000			4000-170-0000	0	P-47
33709-KAB-0030	0	P-109						
33722-KHB4-E000	0	P-109	37200-KKC1-E00	5	P-55			
33725-KHB4-E000	0	P-109	37203-KKC3-900	0	P-55	42000		
33726-KHB4-E000	0	P-109	37204-KKC3-900	0	P-55			
33741-GY6-C300	1	P-65	37211-KKC3-9000	0	P-55	42311-KFC8-9000	2	P-77
33741-KBE-9000	0	P-109	37280-KKC3-9000	0	P-55	42312-KBE-9000	0	P-77
33900-KBF-9000	0	P-89	37720-KGBG-E000	0	P-113	42601-KHD8-90B	1	P-77
			37750-PC1-0050	0	P-41	42710-KKC3-900	0	P-77
			37760-KGBG-E100	0	P-113	42753-004-9000	0	P-77
34000			37760-KHD8-9000	0	P-121	42753-KCX-9000	1	P-73
			37801-GA7-7000	1	P-83			
34901-KED9-900	0	P-53	37802-GA7-7000	2	P-83			
34903-KCP-9000	0	P-53	3780A-KKC3-9000	0	P-83	43000		
34903-KCP-9000	0	P-109						
34905-KCP-9000	0	P-105				43100-KBE-910	0	P-77
34906-KCP-9000	0	P-109	38000			43126-KKC2-E000	1	P-61
34908-MB9-8710-M1	0	P-55				43150-KBE-3060	0	P-77
34909-KBF-9000	0	P-89	38110-KKC3-90A	1	P-113	43156-KKC3-9000	0	P-61

零 件 號 碼 索 引

PART NO. INDEX

零 件 號 碼 PART NO.	版 數 VERSION	頁 次 PAGE	零 件 號 碼 PART NO.	版 數 VERSION	頁 次 PAGE	零 件 號 碼 PART NO.	版 數 VERSION	頁 次 PAGE
43156-KKC4-9000	1	P-61	45131-166-0160	0	P-77	50191-KKC4-9000	0	P-117
43210-KBE-900	0	P-77	45131-GE2-0060	1	P-73	50197-KKC4-9000	0	P-83
43215-KBE-9000	0	P-77	45131-GE2-0060	1	P-77	50301-KN7-6710	2	P-117
43351-KHE7-E00	1	P-77	45132-166-0160	0	P-73	50302-268-0110	0	P-117
43352-568-0030	3	P-73	45132-166-0160	0	P-77	50306-196-0010	0	P-71
43352-568-0030	3	P-77	45133-MA3-0060	0	P-73	50326-KKC4-900	0	P-87
43353-461-7710-M1	0	P-73	45133-MA3-0060	0	P-77	50328-KBN-2000	0	P-87
43353-461-7710-M1	0	P-77	45150-LLB5-3050	0	P-73	5032A-KKC4-9000	0	P-87
43416-KKC4-900	0	P-109	45156-KCE-9000	1	P-71	50350-KKC3-9000	1	P-117
43530-KFC8-3050	1	P-61	45200-KKC2-E00	1	P-73	50352-GY6-9000	0	P-117
			45209-GE2-0060	0	P-73	50356-KHE7-E000	0	P-117
			45209-GE2-0060	0	P-77	50502-GY6-9010	0	P-101
44000			45210-KHD8-9000	0	P-73	50504-KKC3-9000	2	P-15
			45215-KCE-9000	0	P-75	50505-KKD7-9000	0	P-101
44301-KCX-900	1	P-73	45215-KCE-9000	0	P-79	5050A-KKC3-900	5	P-101
44311-KBE-9000	0	P-73	45216-166-0060	0	P-75	50530-KKC4-E00	1	P-101
44620-KHD8-9000	0	P-73	45216-166-0060	0	P-79	50531-KEB7-E000	1	P-101
44650-KHD8-30A	1	P-73	45216-KW6-9020-M1	0	P-75	50532-KGBG-E000	1	P-101
44710-KKC4-900	2	P-73	45216-KW6-9020-M1	0	P-79	50550-KEB7-E000	1	P-101
44800-KFA5-9000	1	P-73	45351-KHE7-E000	0	P-75	50613-KKC4-900	1	P-117
44830-KKC4-9000	2	P-55	45513-KCX-M000-US	1	P-61	5061A-KKC3-900	1	P-117
44831-KKC4-9000	0	P-55	45517-KAF-9100	0	P-61			
			45530-KFC8-E000-IT	2	P-61			
			45531-GR1-9510	0	P-75	51000		
45000			45531-GR1-9510	0	P-79			
			46514-KBF-9000	0	P-89	51400-KKC4-900	2	P-71
45107-MN5-0070	0	P-73				51401-KHD8-9000	0	P-125
45107-MN5-0070	0	P-77				51410-KHD8-9000	0	P-125
45108-ML4-0060	2	P-73	50100			51411-KHD8-9000	0	P-125
45108-ML4-0060	2	P-77				51412-KHD8-9000	0	P-125
45109-GE2-0060	0	P-73	50100-KKC2-EZ0	0	P-117	51413-KHD8-9000	0	P-125
45109-GE2-0060	0	P-77	50139-KKC4-9000	0	P-83	51420-KKC4-9000	0	P-125
45126-KKC2-9000	1	P-61	50151-KKC4-9000	0	P-117	51422-KKC4-900	0	P-125
45128-KBE-9000	0	P-61	50185-KKC4-9000	0	P-117	51423-KAK-9000	0	P-125
45131-166-0160	0	P-73	50186-KKC4-9000	0	P-117	51427-KAK-9000	0	P-125

零 件 號 碼 索 引

PART NO. INDEX

零 件 號 碼 PART NO.	版 數 VERSION	頁 次 PAGE	零 件 號 碼 PART NO.	版 數 VERSION	頁 次 PAGE	零 件 號 碼 PART NO.	版 數 VERSION	頁 次 PAGE
51428-KAK-9000	0	P-125	53224-KKC4-900	0	P-65	77220-KKC4-910	0	P-81
51429-KHD8-9000	0	P-125				77235-KKC4-9000	0	P-89
5150A-KKC4-900	3	P-71				77240-KKC4-9000	1	P-89
51520-KKC4-9000	0	P-125	61000			77300-KKC4-900	3	P-81
						77305-KKC4-9000	1	P-81
52000			61110-KHD8-900	2	P-71			
						80000		
52000-KKC3-900	2	P-103	64000					
52400-KKC2-E00	2	P-103				80100-KKC4-900	3	P-109
52500-KKC2-E00	3	P-103	64220-KKC4-9000	0	P-65	80101-KKC4--900	1	P-109
			64221-KKC4-9000	0	P-65	80102-KKC4-900	2	P-109
53000			64222-KKC4-9000	3	P-65	80105-KKC4-9000	1	P-109
			64301-KKC4-900	0	P-65	80106-KKC4-9000	0	P-109
			64302-KKC4-900	0	P-65	80151-KKC4-900	0	P-89
53100-KKC4-9000	0	P-57	64305-KKC4-900	1	P-65			
53105-KKC4-900	0	P-57	64306-KKC4-900	2	P-65			
53106-KKC4-900	0	P-57	64309-KKC4-9000	0	P-65	81000		
53125-GN5-9010	0	P-57	64310-KKC4-900	0	P-65			
53140-KKC3-900	0	P-57	64311-KKC4-900	3	P-65	81131-KKC4-900	0	P-67
53166-KGB5-900	0	P-57	64312-KKC4-900	3	P-65	81132-KEB7-900	0	P-67
53175-KFA5-E10	0	P-61	64315-KKC4-9000	1	P-117	81136-KKC4-900	0	P-67
53178-KFC8-E10	0	P-61	64317-KKC4-9000	0	P-65	81137-KKC4-900	0	P-67
53200-KKC2-9000	1	P-71	64318-KKC4-9000	0	P-121	81147-KKC4-900	0	P-67
53204-KKC4-900	2	P-65	64320-KKC4-900	0	P-65	81151-KKC4-9000	0	P-89
53205-KKC4-900	0	P-57	64321-KKC4-900	2	P-65	81201-KKC4-900	1	P-89
53206-KKC4-900	0	P-57	64322-KKC4-900	1	P-65	81202-KKC4-900	0	P-89
53207-KKC4-900	0	P-57	64327-KKC4-900	0	P-55	8120A-KKC4-900	6	P-89
53208-KKC4-900	0	P-57	64400-KKC4-900	0	P-65	81257-KKC4-800	0	P-89
53209-KKC4-9000	0	P-57				81260-KKC4-9000	1	P-89
53211-GY6-9400	0	P-71				81400-KKC4-900	0	P-89
53212-250-0110	0	P-71	77000			81500-KKC4-900	0	P-89
53214-250-0010	0	P-71						
53214-KKC4-900	0	P-65	77200-KKC4-E10	0	P-81			
53215-250-0010	0	P-71	77210-KKC4-900	0	P-81			

零件號碼索引

PART NO. INDEX

零件號碼 PART NO.	版數 VERSION	頁次 PAGE	零件號碼 PART NO.	版數 VERSION	頁次 PAGE	零件號碼 PART NO.	版數 VERSION	頁次 PAGE
83000			88115-KKC4-9000	0	P-57	90106-KHE7-E000	0	P-117
			88116-KKC4-9000	3	P-57	90106-KKC4-900	0	P-91
83500-KKC4-900	0	P-89	88120-KKC3-900	4	P-57	90108-KFC8-E000	0	P-101
83600-KKC4-900	1	P-89	88125-KKC4-9000	0	P-57	90110-KEB7-9000	0	P-71
8360A-KKC4-9000	0	P-93	88126-KKC4-9000	3	P-59	90110-KHD8-9000	0	P-97
83750-KKC4-900	1	P-89	88130-KKC4-9000	0	P-59	90111-187-0000	1	P-91
8376A-KBE-900	3	P-67	88135-KKC4-9000	1	P-59	90112-KBN-9010	0	P-87
						90112-KBN-9010	0	P-109
						90112-KDR-9000	0	P-115
86000			89000			90114-166-0070	1	P-61
						90114-GM4-0110	1	P-93
86030-KKC4-E00	0	P-131	89010-KKC4-900	0	P-81	90114-KCX-9000	0	P-93
86102-KFA6-E00	0	P-67	89013-KFC8-E000	1	P-81	90116-KHD8-9000	0	P-125
86202-KKC4-900	0	P-131	89020-KKC4-900	0	P-81	90117-KED9-900	0	P-117
86212-KHD4-E00	0	P-131				90121-KHE7-E000	0	P-117
86212-KKC4-900	0	P-131				90122-KBE-9000	0	P-75
			90000			90131-GW0-9110	0	P-79
						90131-KAF-9000	0	P-103
87000			90001-GHB-6610	0	P-123	90145-MS9-6120-M1	0	P-61
			90012-333-0010	0	P-21	90201-KR8-7520-M1	0	P-41
87224-KKC1-EZ0	0	P-129	90021-GY6-9000	0	P-97	90202-KN7-6710	0	P-35
87311-KKD6-E00	0	P-131	90031-KBE-9000	0	P-15	90206-001-0010	0	P-21
87505-KHE7-E00	0	P-129	90032-KBE-9000	0	P-17	90215-GM0-9100	0	P-97
87508-KKC4-E00	0	P-67	90033-GY6-9000	0	P-21	90215-KKC4-900	0	P-91
87512-KBE-E00	0	P-129	90033-GY6-9410	0	P-21	90301-634-6700	0	P-109
87541-GR1-E00	0	P-129	90084-428-0010	0	P-29	90301-GY6-9010	1	P-97
87541-KKC2-E00	0	P-129	9008A-KE2-9000	0	P-29	90302-GR2-0000	1	P-67
87542-GR1-E00	1	P-129	90105-KBN-9010	0	P-89	90302-GR2-0000	1	P-123
87560-GY6-E00	3	P-129	90105-KEC8-9000	0	P-89	90302-GY6-9010	0	P-59
			90105-KN5-0010	0	P-91	90302-GY6-9010	0	P-67
			90105-KR3-0010	1	P-75	90302-GY6-9010	0	P-123
88000			90105-KR3-0010	1	P-79	90302-GY6-9400	0	P-55
			90106-GN5-9010	0	P-59	90302-GY6-9400	0	P-67
88110-KKC3-900	4	P-57	90106-KFA6-9000	0	P-59	90302-GY6-9400	0	P-91
88114-KKC4-9000	3	P-57	90106-KFC2-9000	0	P-91	90302-GY6-9400	0	P-109

零 件 號 碼 索 引

PART NO. INDEX

零 件 號 碼 PART NO.	版 數 VERSION	頁 次 PAGE	零 件 號 碼 PART NO.	版 數 VERSION	頁 次 PAGE	零 件 號 碼 PART NO.	版 數 VERSION	頁 次 PAGE
90302-SA4-0040	1	P-91				92000		
90304-438-0000	2	P-21	91000					
90304-GE8-0040	1	P-59			P-35	92000-05032-0H	0	P-43
90304-GE8-0040	1	P-117	91001-GY6-90A	0	P-43	92000-06028-0H	0	P-39
90305-GK8-0010	0	P-91	91001-KJ9-006	0	P-35	92900-06045-0B	0	P-21
90305-KW6-9120-M2	0	P-79	91002-GA7-70A	0	P-31			
90306-GW0-9020-M1	0	P-75	91003-KS4-004	0	P-21			
90381-GZ5-0010	0	P-91	91008-GE0-006	0	P-21	93000		
90401-KJ9-0010	0	P-43	91008-KDU-900	0	P-31			
90403-KN7-6710	0	P-35	91009-GE0-0040	0	P-103	93404-06016-07	0	P-67
90411-KM1-0010	0	P-31	91051-KBF-901	0	P-37	93404-06016-07	0	P-111
90412-329-0010	0	P-17	91101-179-7110-M1	0	P-17	93404-06016-07	0	P-123
90421-KM1-0030	0	P-25	91104-KN7-6710	0	P-31	93404-06020-07	0	P-67
90423-KJ9-0010	0	P-43	91105-KN7-6720-Y1	0	P-43	93404-KKC2-900	0	P-67
90446-357-0010	0	P-31	91201-KJ9-0040	0	P-17	93500-03010-1A	0	P-39
90451-GN2-6010	0	P-17	91202-KJ9-0040	0	P-35	93500-04008-1H	0	P-47
90465-MC4-0010	0	P-21	91211-KBE-9000	0	P-31	93500-04012-1A	0	P-91
90474-333-0010	0	P-31	91255-GE0-0060	0	P-103	93500-04014-1H	0	P-47
90478-700-0010	0	P-21	91259-KBF-9000	0	P-17	93500-04020-0G	0	P-115
90478-700-0010	0	P-43	91261-415-0040	0	P-21	93500-05016-0H	0	P-43
9052A-GY6-9500	0	P-17	91301-028-0010	0	P-43	93500-05016-1B	0	P-59
90544-KEC8-9000	0	P-125	91301-KV7-6710	0	P-29	93500-05025-1B	0	P-59
90545-300-0010	2	P-61	91302-001-0210	0	P-29	93500-05032-1B	0	P-59
90605-166-7210	0	P-35	91302-567-0040	0	P-43	93500-05045-1B	0	P-59
90656-GY6-9110	0	P-59	91302-567-0040	0	P-29	93500-KHC4-90A	0	P-115
90656-KDU-9000	0	P-115	91303-377-0010	0	P-29	93600-04012-1G	0	P-61
90656-KDU-9000	0	P-127	91307-035-0010	0	P-37	93700-05018-0H	0	P-55
90677-GR1-0030	1	P-67	91309-425-0040	0	P-35	93891-05012-07	0	P-67
90677-GR1-0030	1	P-111	91384-KBE-9000	0	P-93	93891-05016-08	0	P-93
90701-HB6-0110	0	P-25	91407-SA7-0040	0	P-111	93891-05030-07	0	P-111
90754-GC8-0000	0	P-75	91508-KV7-6710-M1	0	P-37	93892-04006-08	0	P-39
90912-KLF-00B	0	P-75	91981-KN7-6700	0		93892-04008-18	0	P-47
90913-KKC4-9000	0	P-123				93893-04012-18	0	P-61
90915-KKC4-9000	0	P-55				93901-32220	0	P-105
						93901-32310	0	P-105

零件號碼索引

PART NO. INDEX

零件號碼 PART NO.	版數 VERSION	頁次 PAGE	零件號碼 PART NO.	版數 VERSION	頁次 PAGE	零件號碼 PART NO.	版數 VERSION	頁次 PAGE
93901-34220	0	P-107	94050-08080	0	P-115	95002-02070	0	P-127
93901-34320	0	P-111	94050-12080	0	P-35	95002-02080	0	P-31
93903-25480	0	P-93	94101-06200	0	P-97	95002-02080	0	P-85
93903-34380	0	P-59	94101-KBE-9000	0	P-97	95002-02100	0	P-85
93903-34380	0	P-67	94111-05800	0	P-39	95002-02100	0	P-123
93903-34380	0	P-91	94111-06800	0	P-97	95002-02130	0	P-85
93903-34380	0	P-93	94301-08140	0	P-17	95002-02130	0	P-95
93903-34380	0	P-107	94301-08140	0	P-29	95002-50000	0	P-55
93903-34380	0	P-111	94301-08140	0	P-31	95002-70000	0	P-123
93903-34380	0	P-117	94301-08140	0	P-43	95002-KHE7-9000	0	P-123
93903-34380	0	P-123	94301-10160	0	P-23	95002-KN7-9100	1	P-27
93903-35220	0	P-83	94301-10160	0	P-25	95002-KN7-9100	1	P-43
93903-35220	0	P95	94303-04065	0	P-39	95002-KN7-9100	1	P-123
93903-35380	0	P-53	94510-10000	0	P-39	95701-06012-08	0	P-53
93903-35380	0	P-59	94510-15000	0	P-23	95701-06012-08	0	P-61
93903-35380	0	P-91	94510-20000	0	P-31	95701-06012-08	0	P-71
93903-GY6-9000	0	P-67	94511-14000	0	P-17	95701-06012-08	0	P-85
93903-GY6-9000	0	P-87	94520-26000	0	P-43	95701-06012-08	0	P-87
93903-GY6-9000	0	P-91	94520-28000	0	P-35	95701-06012-08	0	P-91
93903-KEB7-9000	0	P-67	94524-42000	0	P-103	95701-06012-08	0	P-119
93903-KEB7-9000	0	P-111	94591-27000	0	P-69	95701-06012-08	0	P-123
			94591-KBF-9000	0	P-23	95701-06014-08	0	P-85
			94591-KBF-9000	0	P-43	95701-06016-07	0	P-123
94000			94601-15000-M1	0	P25	95701-06016-08	0	P-123
			94601-33000	0	P-35	95701-06022-07	0	P-63
94050-05080	0	P-111	94605-KHD8-9000	0	P-125	95701-06022-07	0	P-101
94050-06080	0	P-21	94608-30000	0	P-125	95701-06025-08	0	P-23
94050-06080	0	P-61				95701-08012-08	0	P-17
94050-06080	0	P-69				95701-08012-08	0	P-31
94050-06080	0	P-81	95000			95701-08012-08	0	P-119
94050-06080	0	P-83				95701-08030-08	0	P-103
94050-06080	0	P-87	95001-35225-40	0	P-123	95701-08050-08	0	P-119
94050-06080	0	P-115	95002-02070	0	P-23	95701-KHC5-E000-IT	3	P-115
94050-06080	0	P-123	95002-02070	0	P-85	95801-08040-08	0	P-71
94050-08080	0	P-21	95002-02070	0	P-123	95801-08042-07	0	P-97

零件號碼索引

PART NO. INDEX

零件號碼 PART NO.	版數 VERSION	頁次 PAGE	零件號碼 PART NO.	版數 VERSION	頁次 PAGE	零件號碼 PART NO.	版數 VERSION	頁次 PAGE
95801-08065-07	0	P-97	96220-60100	0	P-39	W1506-032-9910	0	P-47
95801-10025-08	0	P-101	96600-08015-10	1	P-39	W1536-110-9900	0	P-47
95801-10035-08	0	P-103				W1561-107-9920	0	P-47
			98000			W1711-518-9901	0	P-47
96000			98069-5791R-00	0	P-23	W1711-769-9910	0	P-47
96001-06008-07	0	P-97	98200-31000	0	P-87	W1782-013-9900	0	P-47
96001-06010-08	0	P-43	98200-31000	0	P-115	W1795-157-9900	0	P-49
96001-06010-08	0	P-99	98200-31500	0	P-87	W9535-25000	0	P-49
96001-06014-08	0	P-39	98200-31500	0	P-115	W9535-45000	0	P-49
96001-06014-08	0	P-85	98200-32000	0	P-87			
96001-06016-08	0	P-17	98200-32000	0	P-115			
96001-06016-08	0	P-23						
96001-06016-08	0	P-39						
96001-06018-08	0	P27	99000					
96001-06018-08	0	P-43						
96001-06020-08	0	P-43	99101-393-1020	0	P-47			
96001-06022-08	0	P-43						
96001-06025-08	0	P-23						
96001-06028-02	0	P-43	D					
96001-06032-08	0	P-23						
96001-06035-08	0	P-31	D1310-853-0100	0	P-47			
96001-06040-08	0	P-17	D30AV-AR4-0100	0	P-47			
96001-06040-08	0	P-29						
96001-06040-08	0	P-31						
96001-06045-08	0	P-29	N					
96001-06050-08	0	P-17						
96001-06060-08	0	P-17	N413-30B00	0	P-47			
96001-06120-08	0	P-17	N425-9ZA00	0	P-47			
96001-06120-08	0	P-29	W					
96100-60000-00	0	P-43						
96100-62030-00	0	P-17	W1314-014-9901	0	P-47			
96211-05000	0	P-71	W1351-433-9900	0	P-47			
96211-08000	0	P-71	W1446-54B-9900	0	P-47			